



Features

- Low power consumption:30uA (Typ.)
- Low voltage drop:0.15V@100mA(Typ.)
- Standby Mode: 0.1uA
- Low temperature coefficient
- Good line Regulation:0.05%/V
- High Ripple Rejection: 85dB@100Hz(Typ.)
- High input voltage (up to 8V)
- Output voltage accuracy: tolerance $\pm 2\%$
- Build-in Enable/Output Current Limit circuit
- DFN1×1—4、DFN2×2—6、SOT23-5 package

Applications

- Battery-powered equipment
- Communication equipment
- Mobile phones
- Portable games
- Cameras, Video cameras
- Reference voltage sources

General Description

The TX6212 series are highly accurate, low noise, CMOS LDO Voltage Regulators. Offering low output noise, high ripple rejection ratio, low dropout and very fast turn-on times, the TX6212 series is ideal for today's cutting edge mobile phone. Internally the TX6212 includes a reference voltage source, error amplifiers, driver transistors, current limiters and phase compensators.

The TX6212's current limiters' feedback circuit also operates as a short protect for the output current limiter and the output pin. The output voltage is set by current trimming. Voltages are

selectable in 100mV steps within a range of 0.9V to 5.0V.

The TX6212 series is also fully compatible with low ESR ceramic capacitors, reducing cost and improving output stability. This high level of output stability is maintained even during frequent load fluctuations, due to the excellent transient response performance and high PSRR achieved across a broad range of frequencies. The CE function allows the output of regulator to be turned off, resulting in greatly reduced power consumption.

Order Information

TX6212-①②③④

Designator	Symbol	Description
①②	Integer	Output Voltage
③	M5	Package:SOT23-5
	FC	Package:DFN1×1—4
	FB	Package:DFN2×2—6
④	R	RoHS / Pb Free
	G	Halogen Free

Note:“①②” stands for output voltages. Other voltages can be specially customized



Block Diagram

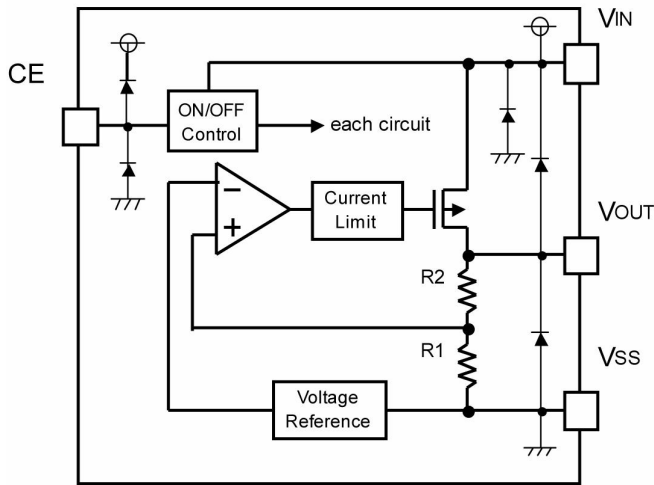

Package and Pin assignment

SOT23-5(Top view)

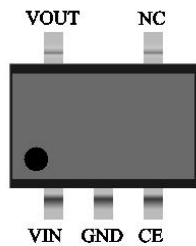

DFN1×1-4(Top view)

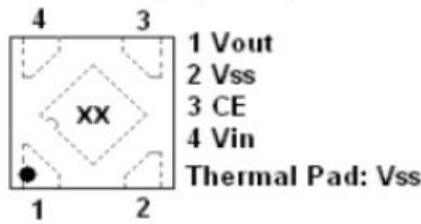

DFN 2*2-6L (Top view)

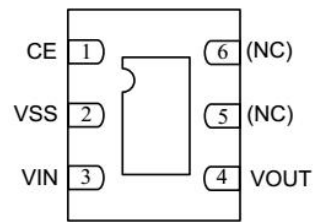

SOT-23-5&DNF2×2-6

PIN NUMBER		SYMBOL	FUNCTION
SOT-23-5	DNF2×2-6		
1	3	V_{IN}	Power Input Pin
2	2	GND	Ground
3	1	CE	Chip Enable Pin
4	5、6	NC	No Connection
5	4	V_{OUT}	Output Pin

DFN1×1-4

PIN NUMBER	SYMBOL	FUNCTION
1	V_{OUT}	Output Pin
2	GND	Ground
3	CE	Chip Enable Pin
4	V_{IN}	Power Input Pin



Marking Rule

MARKING		
VOLTAGE(V)	Package	
	DFN1X1&DFN2X2	SOT23-5
1.2	1V2	LVBX
1.5	1V5	LVEX
1.8	1V8	LVKX
2.5	2V5	LVTX
2.8	2V8	LVXX
3.0	3V0	LVZX
3.3	3V3	LV2Z

① Represents product series

Mark	Product Series
L	TX6212

② Represents type of regulator

Mark		Product series
Vout:0.1~3.3V	Vout:3.4~6.0V	
V	A	TX6212

③ Represents output Voltage

Mark	Output Voltage(V)				Mark	Output Voltage(V)			
0	-	3.1	-	3.15	F	1.6	4.6	1.65	4.65
1	-	3.2	-	3.25	H	1.7	4.7	1.75	4.75
2	-	3.3	-	3.35	K	1.8	4.8	1.85	4.85
3	-	3.4	-	3.45	L	1.9	4.9	1.95	4.95
4	-	3.5	-	3.55	M	2.0	5.0	2.05	-
5	-	3.6	-	3.65	N	2.1	-	2.15	-
6	-	3.7	-	3.75	P	2.2	-	2.25	-
7	-	3.8	-	3.85	R	2.3	-	2.35	--
8	0.9	3.9	0.95	3.95	S	2.4	-	2.45	-
9	1.0	4.0	1.05	4.05	T	2.5	-	2.55	-
A	1.1	4.1	1.15	4.15	U	2.6	-	2.65	-
B	1.2	4.2	1.25	4.25	V	2.7	-	2.75	-
C	1.3	4.3	1.35	4.35	X	2.8	-	2.85	-
D	1.4	4.4	1.45	4.45	Y	2.9	-	2.95	-
E	1.5	4.5	1.55	4.55	Z	3.0	-	3.05	-

④ Represents production lot number

0 to 9, A to Z reverse character of 0 to 9, A to Z repeated (G, I, O, Q, W excepted)



Absolute Maximum Ratings

Supply Voltage-0.3V to 8V Storage Temperature-50°C to 125°C
 Operating Temperature-40°C to 85°C

Note: These are stress ratings only. Stresses exceeding the range specified under “Absolute Maximum Ratings” may cause substantial damage to the device. Functional operation of this device at other conditions beyond those listed in the specification is not implied and prolonged exposure to extreme conditions may affect device reliability.

Thermal Information

Symbol	Parameter	Package	Max.	Unit
θ_{JA}	Thermal Resistance (Junction to Ambient) (Assume no ambient airflow, no heat sink)	SOT23-5	500	°C/W
		DFN1 × 1—4		
		DFN2 × 2—6		
P_D	Power Dissipation	SOT23-5	0.4	W
		DFN1 × 1—4	0.25	
		DFN2 × 2—6	0.3	

Note: P_D is measured at $T_a = 25^\circ\text{C}$



Electrical Characteristics

TX6212 series

(Ta=25°C)

Parameter	Symbol	Conditions	Min.	Typ.	Max.	Unit
Output Voltage	Vout	Vin=Vout+1V 1.0mA≤Iout≤30mA	Vout×0.98	--	Vout×1.02	V
Output Current*1	Iout	Vin-Vout=1V	--	350	--	mA
Line Regulation	$\frac{\Delta V_{out}}{\Delta V_{in}}$ ($\Delta V_{in} \cdot V_{out}$)	4.3V≤Vin≤8V Iout=10mA	--	0.05	0.2	%/V
Load Regulation	ΔV_{out}	Vin= 4.3V 1.0mA≤Iout≤100mA	--	10	30	mV
Output voltage Temperature Coefficient	$\frac{\Delta V_{out}}{(Ta \cdot V_{out})}$	Iout=30mA 0°C≤Ta≤70°C	--	±100	--	Ppm/ °C
Supply Current	Iss1	--	--	30	--	uA
Input Voltage	Vin	--	--	--	8	V
PSRR	PSRR	F=100Hz, Vin=4.3Vdc+1Vpp	--	85	--	dB

Typical Application Circuit

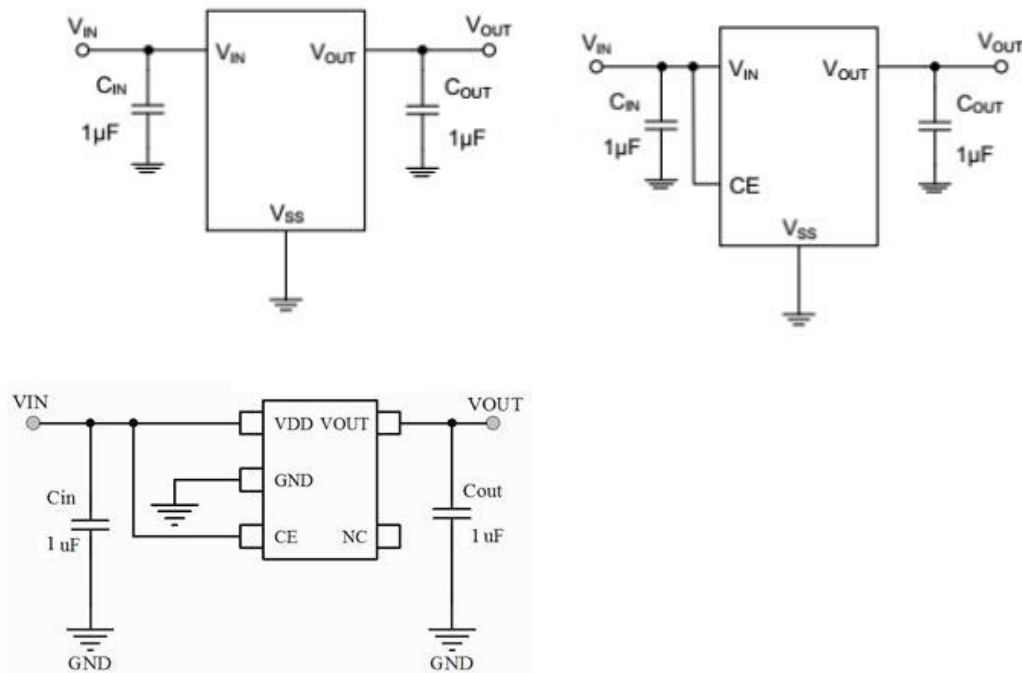



Operational Explanation

<Output Voltage Control>

The voltage divided by resistors R1 & R2 is compared with the internal reference voltage by the error amplifier. The P-channel MOSFET, which is connected to the V_{OUT} pin, is then driven by the subsequent output signal. The output voltage at the V_{OUT} pin is controlled and stabilized by a system of negative feedback. The current limit circuit and short protect circuit operate in relation to the level of output current. Further, the IC's internal circuitry can be shutdown via the CE pin's signal

<Low ESR Capacitors>

With the TX6212 series, a stable output voltage is achievable even if used with low ESR capacitors as a phase compensation circuit is built-in. In order to ensure the effectiveness of the phase compensation, we suggest that an output capacitor (C_L) is connected as close as possible to the output pin (V_{OUT}) and the V_{SS} pin. Please use an output capacitor with a capacitance value of at least 10uF. Also, please connect an input capacitor (C_{IN}) of 10uF between the V_{IN} pin and the V_{SS} pin in order to ensure a stable power input. Stable phase compensation may not be ensured if the capacitor runs out capacitance when depending on bias and temperature. In case the capacitor depends on the bias and temperature, please make sure the capacitor can ensure the actual capacitance.

<Current Limiter, Short-Circuit Protection>

The TX6212 series includes a combination of a fixed current limiter circuit & a feedback circuit, which aid the operations of the current limiter and circuit protection. When the load current reaches the current limit level, the fixed current limiter circuit operates and output voltage drops. As a result of this drop in output voltage, the feedback circuit operates, output voltage drops further and output current decreases. When the output pin is shorted, a current of about 50mA flows.

<CE Pin>

The IC's internal circuitry can be shutdown via the signal from the CE pin with the TX6212 series. In shutdown mode, output at the V_{OUT} pin will be pulled down to the V_{SS} level via R1 & R2. The operational logic of the IC's CE pin is selectable (please refer to the selection guide). Note that as the standard TX6212 type's regulator 1 and 2 are both 'High Active/No Pull-Down', operations will become unstable with the CE pin open. Although the CE pin is equal to an inverter input with CMOS hysteresis, with either the pull-up or pull-down options, the CE pin input current will increase when the IC is in operation. We suggest that you use this IC with either a V_{IN} voltage or a V_{SS} voltage input at the CE pin. If this IC is used with the correct specifications for the CE pin, the operational logic is fixed and the IC will operate normally. However, supply current may increase as a result of through current in the IC's internal circuitry.

Notes on Use

1. Please use this IC within the stated absolute maximum ratings. The IC is liable to malfunction should the ratings be exceeded.
2. Where wiring impedance is high, operations may become unstable due to noise and/or phase lag depending on output current. Please keep the resistance low between V_{IN} and V_{SS} wiring in particular.
3. Please wire the input capacitor (C_{IN}) and the output capacitor (C_L) as close to the IC as possible.



Packaging Information

SOT23-5 Outline Dimensions

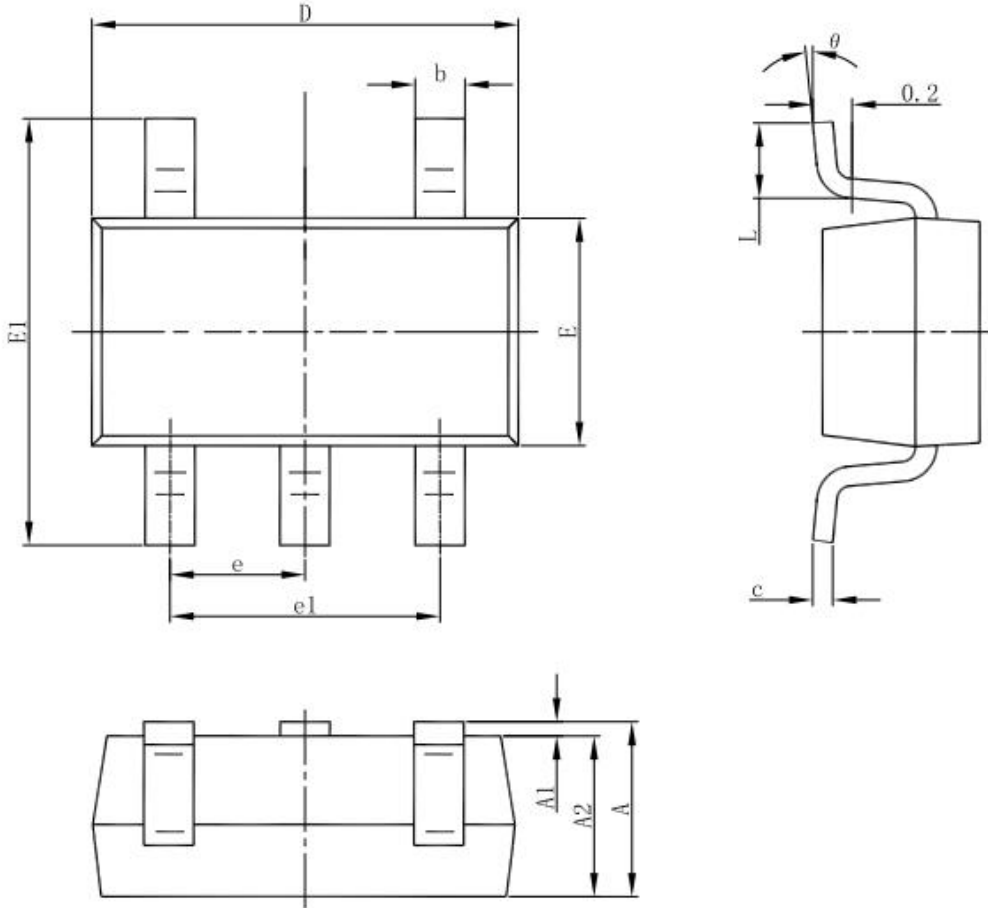

Symbol	Dimensions In Millimeters		Dimensions In Inches	
	Min	Max	Min	Max
A	1.050	1.250	0.041	0.049
A1	0.000	0.100	0.000	0.004
A2	1.050	1.150	0.041	0.045
b	0.300	0.500	0.012	0.020
c	0.100	0.200	0.004	0.008
D	2.820	3.020	0.111	0.119
E	1.500	1.700	0.059	0.067
E1	2.650	2.950	0.104	0.116
e	0.950(BSC)		0.037(BSC)	
e1	1.800	2.000	0.071	0.079
L	0.300	0.600	0.012	0.024
θ	0°	8°	0°	8°



DFN1×1-4 Outline Dimensions

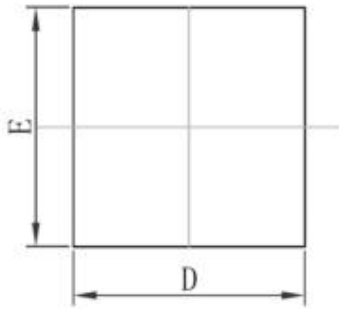

TOP VIEW
 [顶视图]

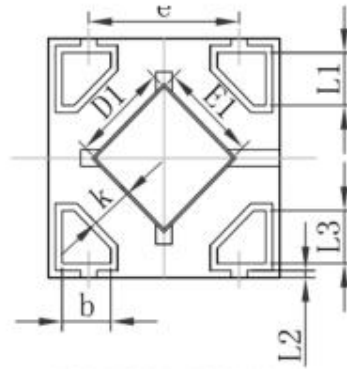

BOTTOM VIEW
 [背视图]

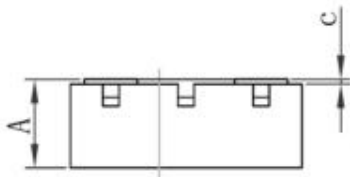

Symbol	Dimensions In Millimeters		Dimensions In Inches	
	Min.	Max.	Min.	Max.
A	0.335	0.405	0.013	0.016
D	0.950	1.050	0.037	0.041
E	0.950	1.050	0.037	0.041
D1	0.370	0.470	0.015	0.019
E1	0.370	0.470	0.015	0.019
k	0.17MIN.		0.007MIN.	
b	0.160	0.260	0.006	0.010
c	0.010	0.090	0.000	0.004
e	0.600	0.700	0.024	0.028
L1	0.185	0.255	0.007	0.010
L2	0.030 REF.		0.001 REF.	
L3	0.185	0.255	0.007	0.010



DFN2×2-6 Outline Dimensions

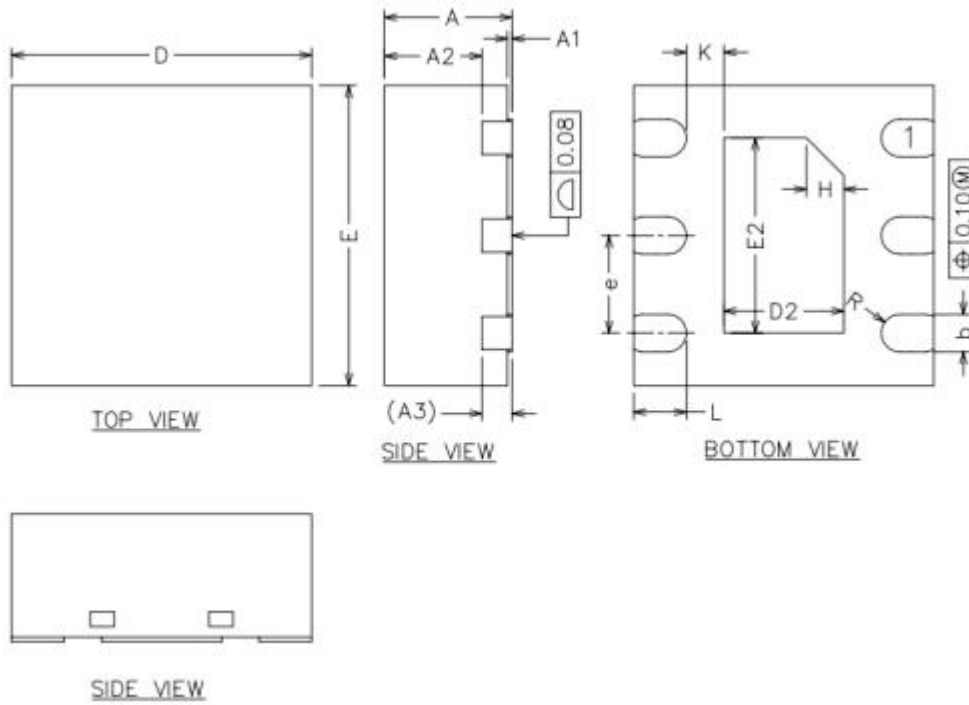

COMMON DIMENSIONS
 (UNITS OF MEASURE=MILLIMETER)

SYMBOL	MIN	NOM	MAX
A	0.80	0.85	0.90
A1	0.00	0.02	0.05
A2	0.60	0.65	0.70
A3	0.20REF		
b	0.18	0.25	0.30
D	1.90	2.00	2.10
E	1.90	2.00	2.10
D2	0.70	0.80	0.90
E2	1.20	1.30	1.40
e	0.55	0.65	0.75
H	0.25REF		
K	0.20	—	—
L	0.30	0.35	0.40
R	0.11	—	—



CBC Microelectronics
<http://www.cbcv.net>

TX6212 Series
High Speed Low Noise LDO

IMPORTANT NOTICE

CBC Microelectronics Co., LTD reserves the right to make changes without further notice to any products or specifications herein. CBC Microelectronics Co., LTD does not assume any responsibility for use of any its products for any particular purpose, nor does CBC Microelectronics Co., LTD assume any liability arising out of the application or use of any its products or circuits. CBC Microelectronics Co., LTD does not convey any license under its patent rights or other rights nor the rights of others.