



Features

- Low power consumption
- Low voltage drop
- Low temperature coefficient
- High input voltage (up to 15V)
- Output voltage accuracy: tolerance $\pm 2\%$
- TO92, SOT89, SOT23-3 and SOT23 package

Applications

- Battery-powered equipment
- Communication equipment
- Audio/Video equipment

General Description

The TX71XXM series is a set of three-terminal low power high voltage regulators implemented in CMOS technology. They allow input voltages as high as 15V. They are available with several fixed output voltages ranging from 2.1V to 5.0V. CMOS technology ensures low voltage drop and low quiescent current. Although designed primarily as fixed voltage regulators, these devices can be used with external components to obtain variable voltages and currents.

Selection Table

Part No.	Output Voltage	Package	Marking
TX7121Mxx	2.1V	TO92 SOT89 SOT23-3 SOT23	71XXA-1(for TO92) 71XX-1(for SOT89) HTXX(for SOT23-3) HTXX(for SOT23)
TX7123Mxx	2.3V		
TX7125Mxx	2.5V		
TX7127Mxx	2.7V		
TX7130Mxx	3.0V		
TX7133Mxx	3.3V		
TX7136Mxx	3.6V		
TX7144Mxx	4.4V		
TX7150Mxx	5.0V		

Order Information

TX71①②③④⑤

Designator	Symbol	Description
① ②	Integer	Output Voltage(2.1~5.0V)
③	M	Standard
④	T	Package:TO-92
	P	Package:SOT89
	M	Package:SOT23-3
	N	Package:SOT23
⑤	R	RoHS / Pb Free
	G	Halogen Free



Block Diagram

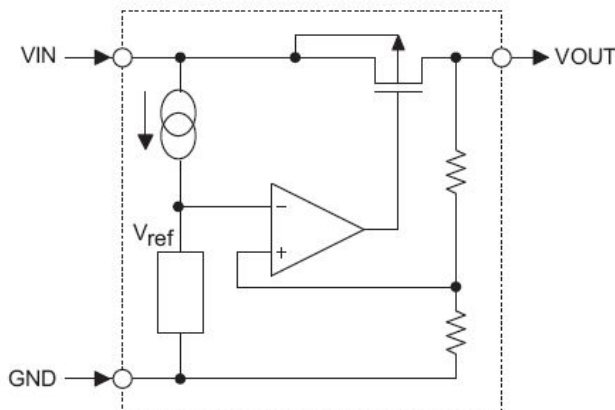

Pin Assignment

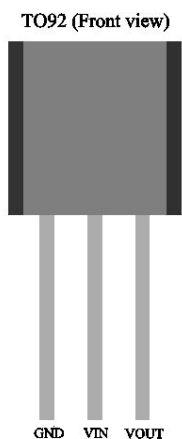

SOT89 (Top view)

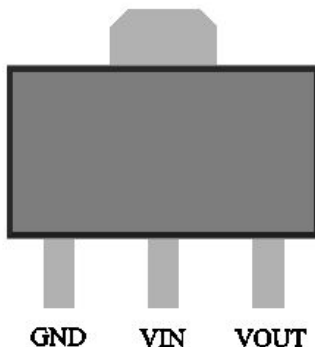

SOT23-3 and SOT23 (Top view)

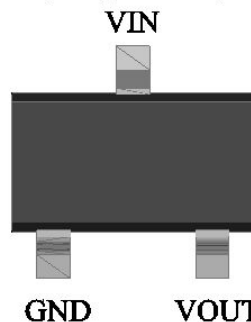

Absolute Maximum Ratings

Supply Voltage-0.3V to 18V Storage Temperature-50°C to 125°C
 Operating Temperature-40°C to 85°C

Note: These are stress ratings only. Stresses exceeding the range specified under “Absolute Maximum Ratings” may cause substantial damage to the device. Functional operation of this device at other conditions beyond those listed in the specification is not implied and prolonged exposure to extreme conditions may affect device reliability.

Thermal Information

Symbol	Parameter	Package	Max.	Unit
θ_{JA}	Thermal Resistance (Junction to Ambient) (Assume no ambient airflow, no heat sink)	TO92	200	°C/W
		SOT89	200	°C/W
		SOT23-3	500	°C/W
P_D	Power Dissipation	TO92	0.50	W
		SOT89	0.50	W
		SOT23-3	0.20	W

Note: P_D is measured at $T_a = 25^\circ\text{C}$



Electrical Characteristics

TX7121Mxx, +2.1V Output Type

Symbol	Parameter	Test Conditions		Min.	Typ.	Max.	Unit
		V _{IN}	Conditions				
V _{OUT}	Output Voltage	4.1V	I _{OUT} =10mA	2.058	2.100	2.142	V
I _{OUT}	Output Current	4.1V	-	30	50	-	mA
ΔV _{OUT}	Load Regulation	4.1V	1mA ≤ I _{OUT} ≤ 20mA	-	60	100	mV
V _{DIF}	Voltage Drop(Note)	-	I _{OUT} =1mA	-	100	-	mV
I _{SS}	Current Consumption	4.1V	No load	-	2.5	3	μA
$\frac{\Delta V_{OUT}}{\Delta V_{IN} \times V_{OUT}}$	Line Regulation	-	3.1V ≤ V _{IN} ≤ 16V I _{OUT} =1mA	-	0.2	-	%/V
V _{IN}	Input Voltage	-	-	-	-	15	V
$\frac{\Delta V_{OUT}}{\Delta T_a}$	Temperature Coefficient	4.1V	I _{OUT} =10mA 0°C < T _a < 70°C	-	±0.37	-	mV/°C

Note: Dropout voltage is defined as the input voltage minus the output voltage that produces a 2% change in the output voltage from the value at V_{IN} = V_{OUT}+2V with a fixed load.

TX7123Mxx, +2.3V Output Type

Symbol	Parameter	Test Conditions		Min.	Typ.	Max.	Unit
		V _{IN}	Conditions				
V _{OUT}	Output Voltage	4.3V	I _{OUT} =10mA	2.254	2.300	2.346	V
I _{OUT}	Output Current	4.3V	-	30	50	-	mA
ΔV _{OUT}	Load Regulation	4.3V	1mA ≤ I _{OUT} ≤ 20mA	-	60	100	mV
V _{DIF}	Voltage Drop(Note)	-	I _{OUT} =1mA	-	100	-	mV
I _{SS}	Current Consumption	4.3V	No load	-	2.5	3	μA
$\frac{\Delta V_{OUT}}{\Delta V_{IN} \times V_{OUT}}$	Line Regulation	-	3.3V ≤ V _{IN} ≤ 16V I _{OUT} =1mA	-	0.2	-	%/V
V _{IN}	Input Voltage	-	-	-	-	15	V
$\frac{\Delta V_{OUT}}{\Delta T_a}$	Temperature Coefficient	4.3V	I _{OUT} =10mA 0°C < T _a < 70°C	-	±0.39	-	mV/°C

Note: Dropout voltage is defined as the input voltage minus the output voltage that produces a 2% change in the output voltage from the value at V_{IN} = V_{OUT}+2V with a fixed load.



TX7125Mxx, +2.5V Output Type

Symbol	Parameter	Test Conditions		Min.	Typ.	Max.	Unit
		V _{IN}	Conditions				
V _{OUT}	Output Voltage	4.5V	I _{OUT} =10mA	2.45	2.500	2.55	V
I _{OUT}	Output Current	4.5V	-	30	50	-	mA
ΔV _{OUT}	Load Regulation	4.5V	1mA ≤ I _{OUT} ≤ 20mA	-	60	100	mV
V _{DIF}	Voltage Drop(Note)	-	I _{OUT} =1mA	-	100	-	mV
I _{SS}	Current Consumption	4.5V	No load	-	2.5	3	μA
$\frac{\Delta V_{OUT}}{\Delta V_{IN} \times V_{OUT}}$	Line Regulation	-	3.5V ≤ V _{IN} ≤ 16V I _{OUT} =1mA	-	0.2	-	%/V
V _{IN}	Input Voltage	-	-	-	-	15	V
$\frac{\Delta V_{OUT}}{\Delta Ta}$	Temperature Coefficient	4.5V	I _{OUT} =10mA 0°C < Ta < 70°C	-	±0.41	-	mV/°C

Note: Dropout voltage is defined as the input voltage minus the output voltage that produces a 2% change in the output voltage from the value at V_{IN} = V_{OUT}+2V with a fixed load.

TX7127Mxx, +2.7V Output Type

Symbol	Parameter	Test Conditions		Min.	Typ.	Max.	Unit
		V _{IN}	Conditions				
V _{OUT}	Output Voltage	4.7V	I _{OUT} =10mA	2.646	2.700	2.754	V
I _{OUT}	Output Current	4.7V	-	30	50	-	mA
ΔV _{OUT}	Load Regulation	4.7V	1mA ≤ I _{OUT} ≤ 20mA	-	60	100	mV
V _{DIF}	Voltage Drop(Note)	-	I _{OUT} =1mA, ΔV _{OUT} =2%	-	100	-	mV
I _{SS}	Current Consumption	4.7V	No load	-	2.5	3	μA
$\frac{\Delta V_{OUT}}{\Delta V_{IN} \times V_{OUT}}$	Line Regulation	-	3.7V ≤ V _{IN} ≤ 16V I _{OUT} =1mA	-	0.2	-	%/V
V _{IN}	Input Voltage	-	-	-	-	15	V
$\frac{\Delta V_{OUT}}{\Delta Ta}$	Temperature Coefficient	4.7V	I _{OUT} =10mA 0°C < Ta < 70°C	-	±0.43	-	mV/°C

Note: Dropout voltage is defined as the input voltage minus the output voltage that produces a 2% change in the output voltage from the value at V_{IN} = V_{OUT}+2V with a fixed load.



TX7130Mxx, +3.0V Output Type

Symbol	Parameter	Test Conditions		Min.	Typ.	Max.	Unit
		V _{IN}	Conditions				
V _{OUT}	Output Voltage	5V	I _{OUT} =10mA	2.94	3.00	3.06	V
I _{OUT}	Output Current	5V	-	30	50	-	mA
ΔV _{OUT}	Load Regulation	5V	1mA ≤ I _{OUT} ≤ 20mA	-	20	100	mV
V _{DIF}	Voltage Drop(Note)	-	I _{OUT} =1mA	-	30	-	mV
I _{SS}	Current Consumption	5V	No load	-	2.5	3	μA
$\frac{\Delta V_{OUT}}{\Delta V_{IN} \times V_{OUT}}$	Line Regulation	-	4V ≤ V _{IN} ≤ 16V I _{OUT} =1mA	-	0.02	-	%/V
V _{IN}	Input Voltage	-	-	-	-	15	V
$\frac{\Delta V_{OUT}}{\Delta T_a}$	Temperature Coefficient	5V	I _{OUT} =10mA 0°C < T _a < 70°C	-	±0.45	-	mV/°C

Note: Dropout voltage is defined as the input voltage minus the output voltage that produces a 2% change in the output voltage from the value at V_{IN} = V_{OUT}+2V with a fixed load.

TX7133Mxx, +3.3V Output Type

Symbol	Parameter	Test Conditions		Min.	Typ.	Max.	Unit
		V _{IN}	Conditions				
V _{OUT}	Output Voltage	5.3V	I _{OUT} =10mA	3.234	3.300	3.366	V
I _{OUT}	Output Current	5.3V	-	30	50	-	mA
ΔV _{OUT}	Load Regulation	5.3V	1mA ≤ I _{OUT} ≤ 20mA	-	40	100	mV
V _{DIF}	Voltage Drop(Note)	-	I _{OUT} =1mA	-	30	-	mV
I _{SS}	Current Consumption	5.3V	No load	-	2.5	3	μA
$\frac{\Delta V_{OUT}}{\Delta V_{IN} \times V_{OUT}}$	Line Regulation	-	4.5V ≤ V _{IN} ≤ 16V I _{OUT} =1mA	-	0.06	-	%/V
V _{IN}	Input Voltage	-	-	-	-	15	V
$\frac{\Delta V_{OUT}}{\Delta T_a}$	Temperature Coefficient	5.3V	I _{OUT} =10mA 0°C < T _a < 70°C	-	±0.5	-	mV/°C

Note: Dropout voltage is defined as the input voltage minus the output voltage that produces a 2% change in the output voltage from the value at V_{IN} = V_{OUT}+2V with a fixed load.



TX7136Mxx, +3.6V Output Type

Symbol	Parameter	Test Conditions		Min.	Typ.	Max.	Unit
		V _{IN}	Conditions				
V _{OUT}	Output Voltage	5.6V	I _{OUT} =10mA	3.528	3.600	3.672	V
I _{OUT}	Output Current	5.6V	-	30	50	-	mA
ΔV _{OUT}	Load Regulation	5.6V	1mA ≤ I _{OUT} ≤ 20mA	-	30	100	mV
V _{DIF}	Voltage Drop(Note)	-	I _{OUT} =1mA	-	25	-	mV
I _{SS}	Current Consumption	5.6V	No load	-	2.5	3.0	μA
$\frac{\Delta V_{OUT}}{\Delta V_{IN} \times V_{OUT}}$	Line Regulation	-	4.6V ≤ V _{IN} ≤ 16V I _{OUT} =1mA	-	0.02	-	%/V
V _{IN}	Input Voltage	-	-	-	-	15	V
$\frac{\Delta V_{OUT}}{\Delta T_a}$	Temperature Coefficient	5.6V	I _{OUT} =10mA 0°C < T _a < 70°C	-	±0.6	-	mV/°C

Note: Dropout voltage is defined as the input voltage minus the output voltage that produces a 2% change in the output voltage from the value at V_{IN} = V_{OUT}+2V with a fixed load.

TX7144Mxx, +4.4V Output Type

Symbol	Parameter	Test Conditions		Min.	Typ.	Max.	Unit
		V _{IN}	Conditions				
V _{OUT}	Output Voltage	6.4V	I _{OUT} =10mA	4.312	4.400	4.488	V
I _{OUT}	Output Current	6.4V	-	30	50	-	mA
ΔV _{OUT}	Load Regulation	6.4V	1mA ≤ I _{OUT} ≤ 20mA	-	20	100	mV
V _{DIF}	Voltage Drop(Note)	-	I _{OUT} =1mA	-	20	-	mV
I _{SS}	Current Consumption	6.4V	No load	-	2.5	3.0	μA
$\frac{\Delta V_{OUT}}{\Delta V_{IN} \times V_{OUT}}$	Line Regulation	-	5.4V ≤ V _{IN} ≤ 16V I _{OUT} =1mA	-	0.02	-	%/V
V _{IN}	Input Voltage	-	-	-	-	15	V
$\frac{\Delta V_{OUT}}{\Delta T_a}$	Temperature Coefficient	6.4V	I _{OUT} =10mA 0°C < T _a < 70°C	-	±0.7	-	mV/°C

Note: Dropout voltage is defined as the input voltage minus the output voltage that produces a 2% change in the output voltage from the value at V_{IN} = V_{OUT}+2V with a fixed load.



TX7150Mxx, +5.0V Output Type

Symbol	Parameter	Test Conditions		Min.	Typ.	Max.	Unit
		V _{IN}	Conditions				
V _{OUT}	Output Voltage	7V	I _{OUT} =10mA	4.9	5.00	5.1	V
I _{OUT}	Output Current	7V	-	30	50	-	mA
ΔV _{OUT}	Load Regulation	7V	1mA ≤ I _{OUT} ≤ 20mA	-	25	100	mV
V _{DIF}	Voltage Drop(Note)	-	I _{OUT} =1mA	-	20	-	mV
I _{SS}	Current Consumption	7V	No load	-	2.5	3.0	μA
$\frac{\Delta V_{OUT}}{\Delta V_{IN} \times V_{OUT}}$	Line Regulation	-	6V ≤ V _{IN} ≤ 16V I _{OUT} =1mA	-	0.04	-	%/V
V _{IN}	Input Voltage	-	-	-	-	15	V
$\frac{\Delta V_{OUT}}{\Delta T_a}$	Temperature Coefficient	7V	I _{OUT} =10mA 0°C < T _a < 70°C	-	±0.75	-	mV/°C

Note: Dropout voltage is defined as the input voltage minus the output voltage that produces a 2% change in the output voltage from the value at V_{IN} = V_{OUT}+2V with a fixed load.



Typical Performance Characteristics

(1) Output Voltage vs Input voltage

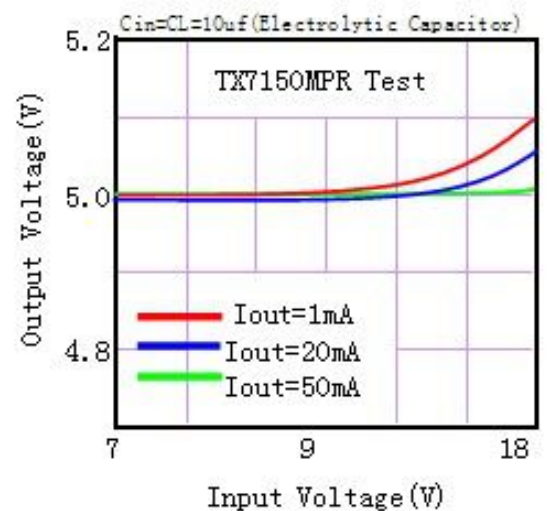
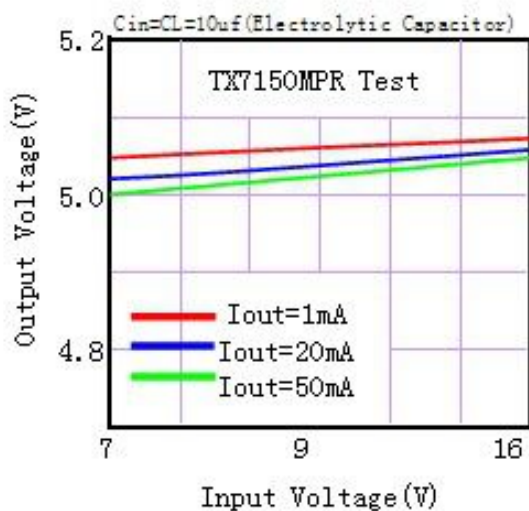
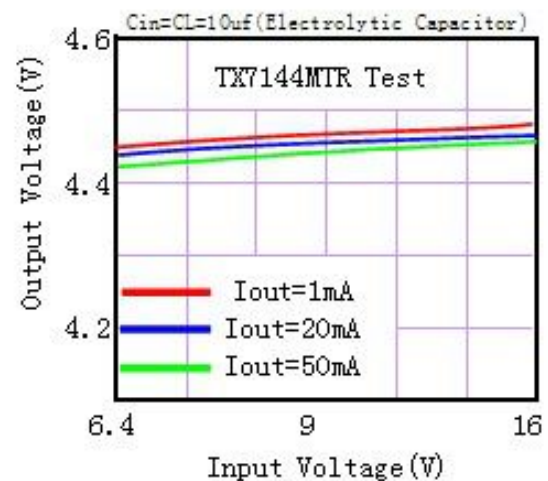
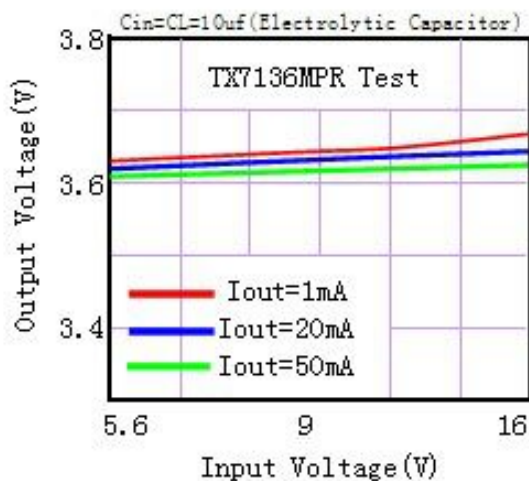
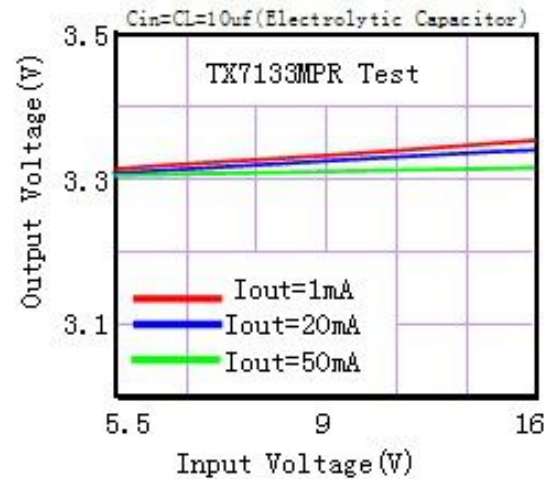
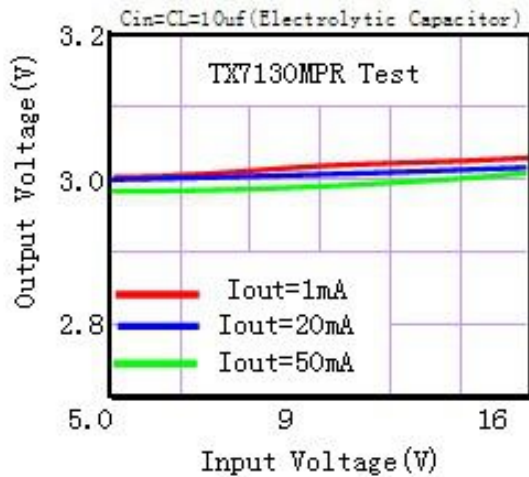



(2) Output Voltage vs. Output Current

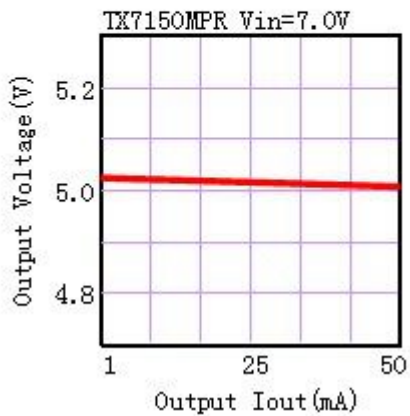
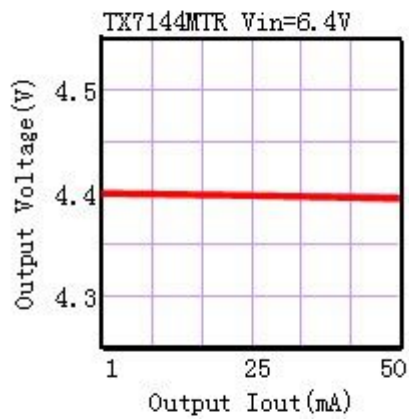
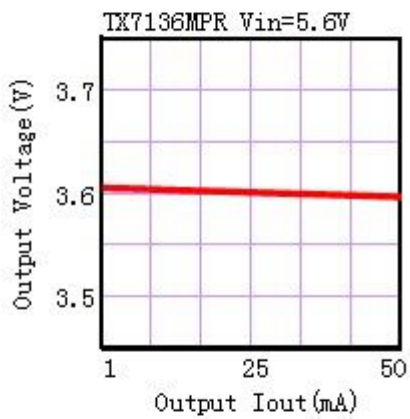
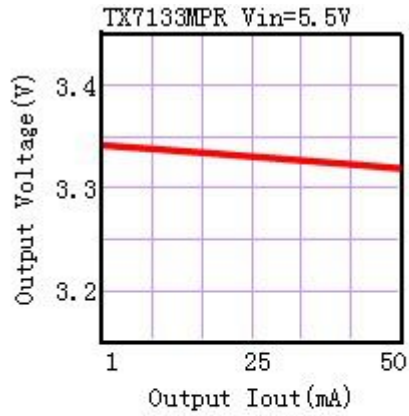
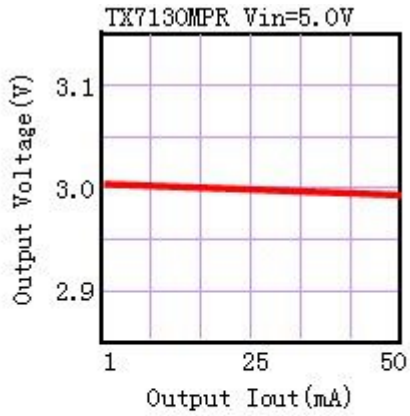



(3) Input Voltage vs. Output Current

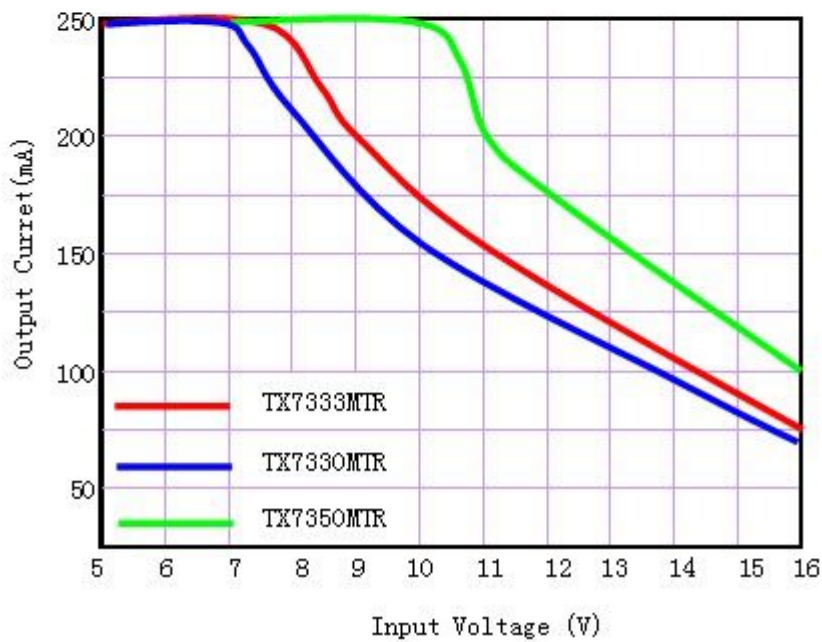
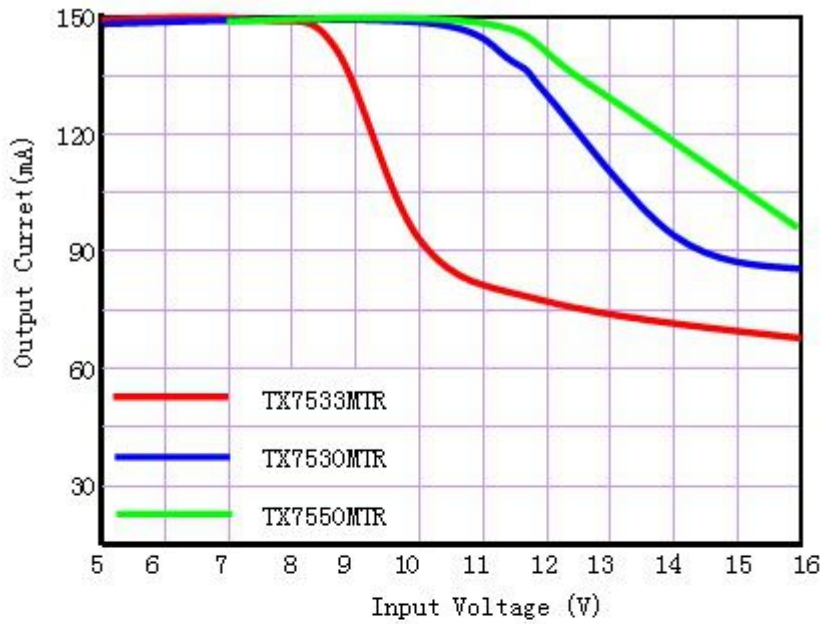



(4) Input Transient Response 1

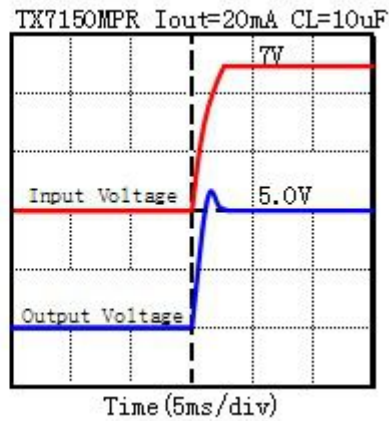
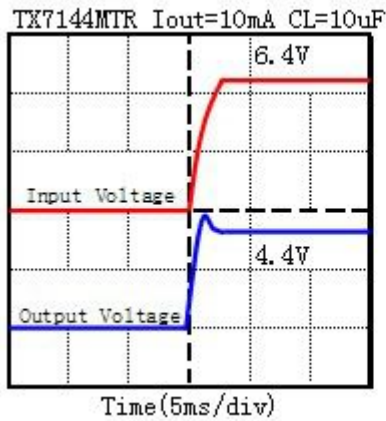
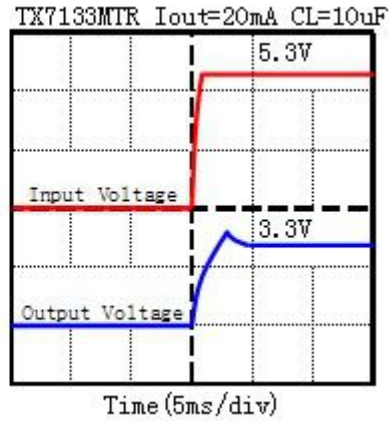
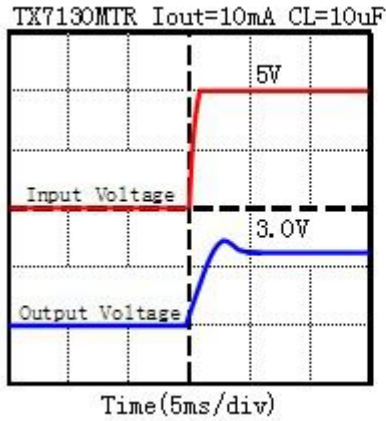

(5) Output Voltage vs.Ambient Temperature

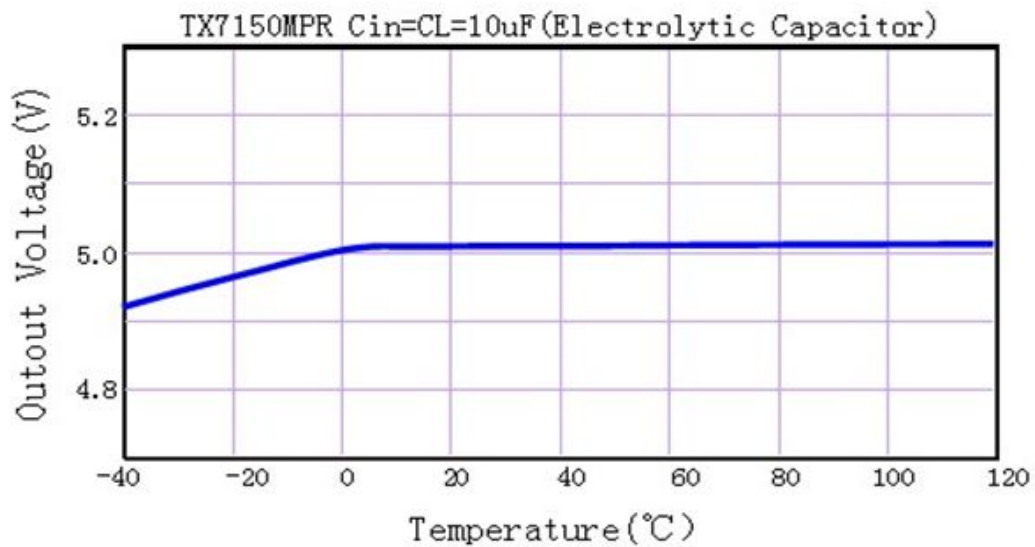



Application Circuits

Basic Circuits

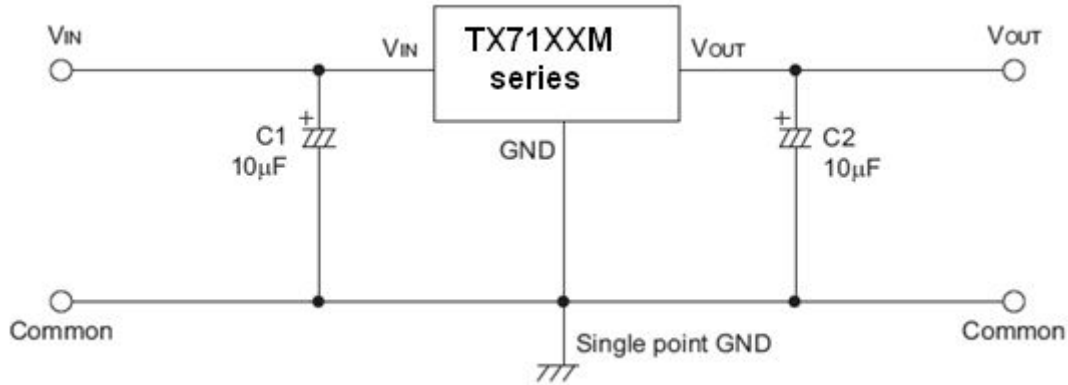

High Output Current Positive Voltage Regulator

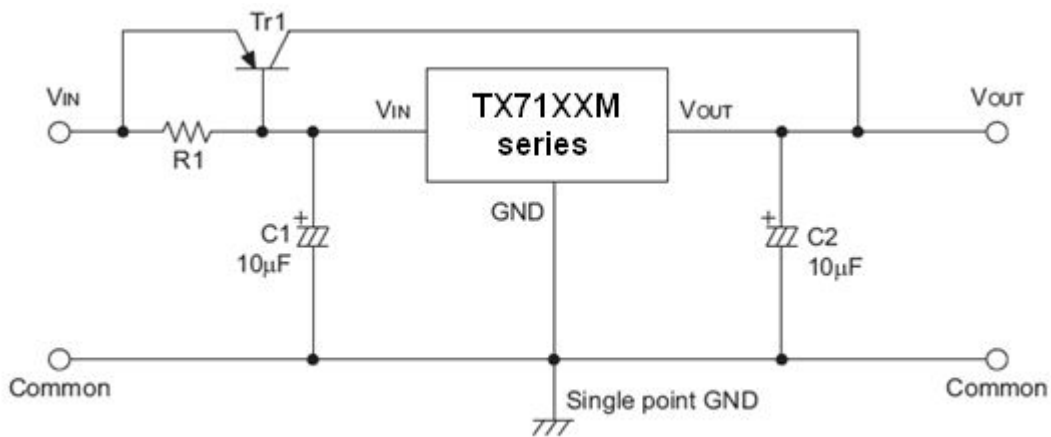

Short-Circuit Protection by Tr1

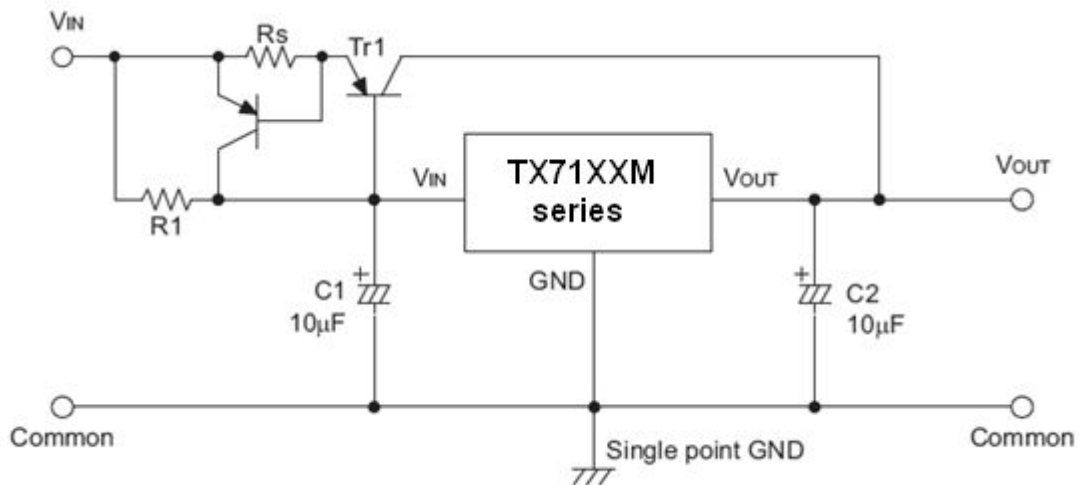



Circuit for Increasing Output Voltage

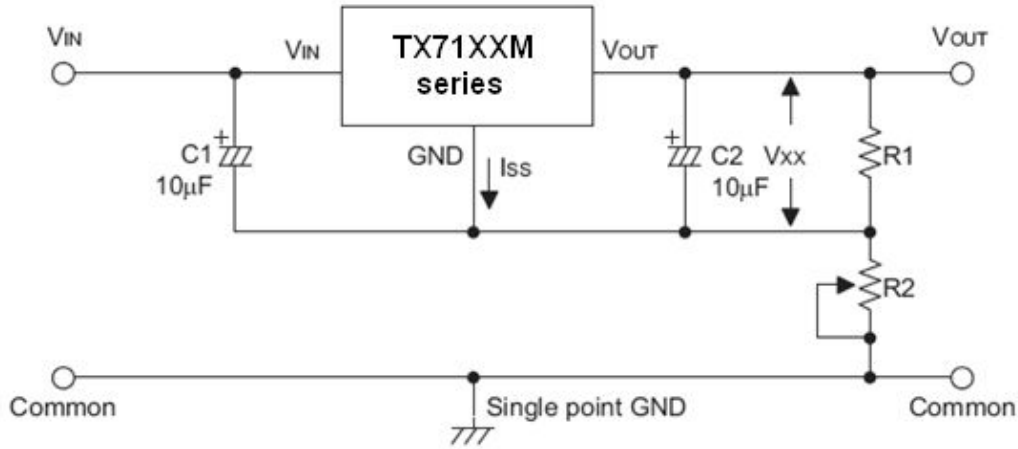

Circuit for Increasing Output Voltage

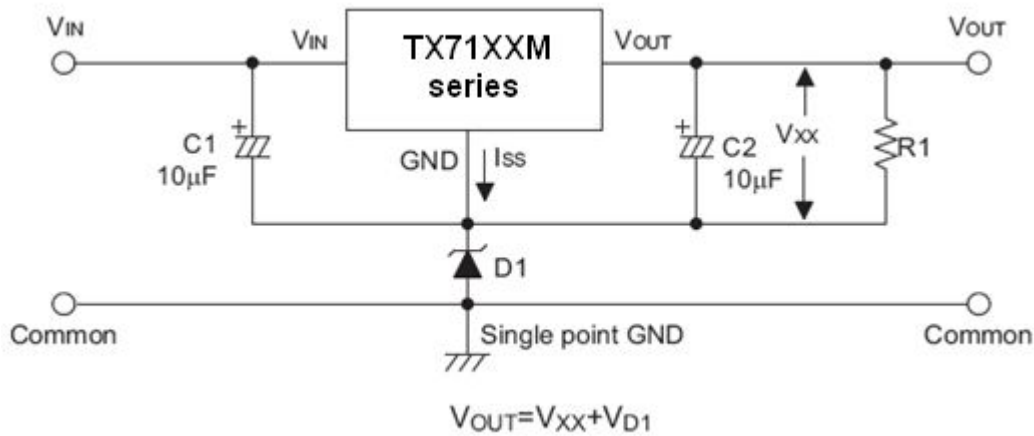

Constant Current Regulator

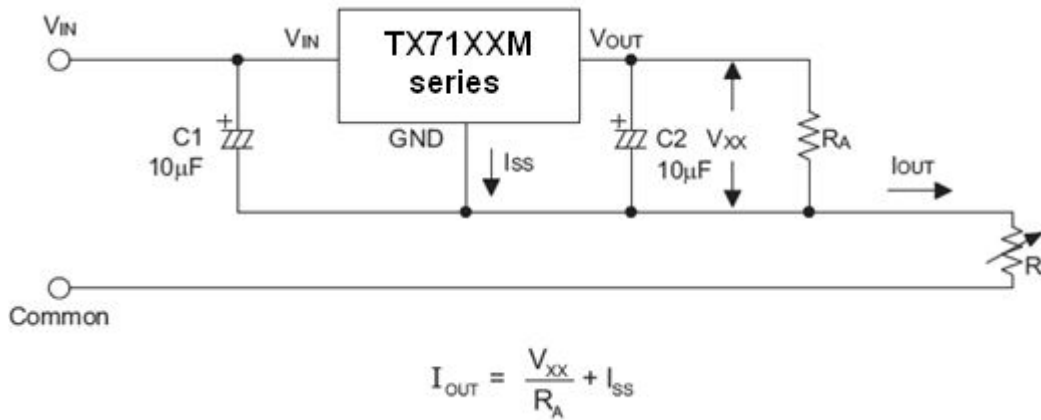



Dual Supply

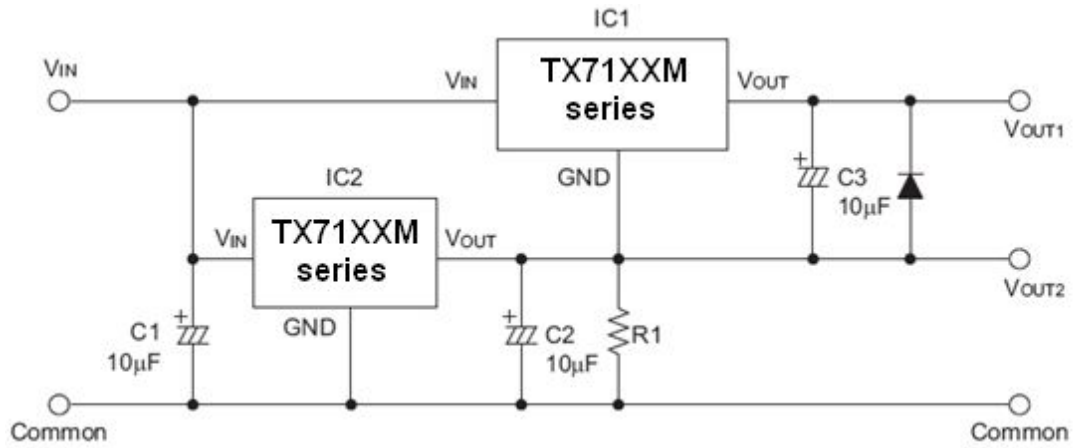



Package Information
3-pin TO92 Outline Dimensions

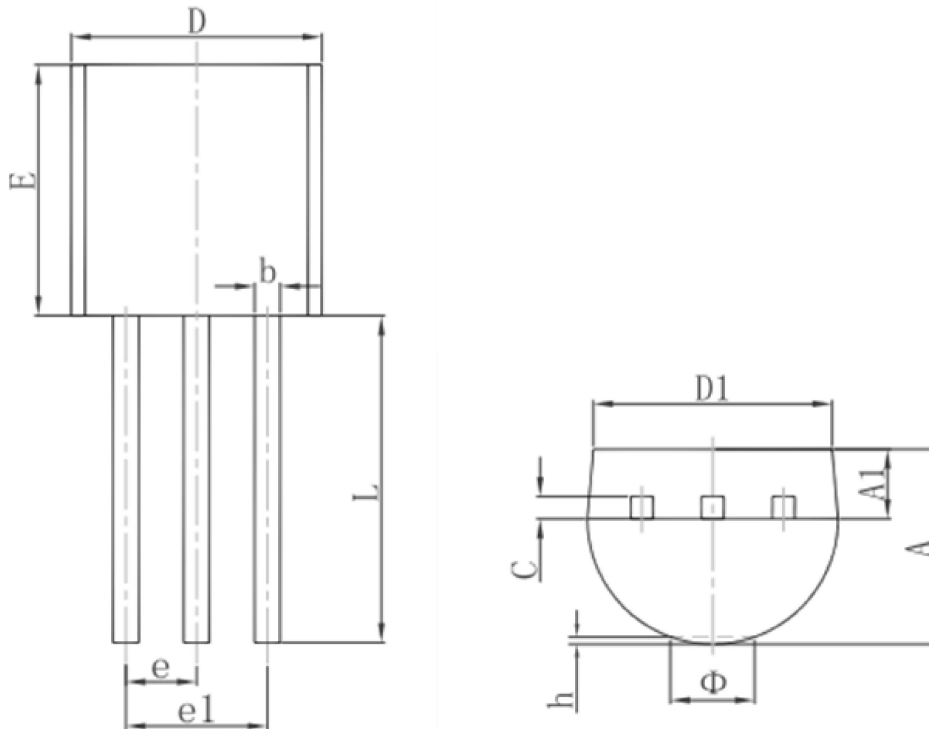

Symbol	Dimensions In Millimeters		Dimensions In Inches	
	Min.	Max.	Min.	Max.
A	3.300	3.700	0.130	0.146
A1	1.100	1.400	0.043	0.055
b	0.380	0.550	0.015	0.022
c	0.360	0.510	0.014	0.020
D	4.300	4.700	0.169	0.185
D1	3.430		0.135	
E	4.300	4.700	0.169	0.185
e	1.270 TYP.		0.050 TYP.	
e1	2.440	2.640	0.096	0.104
L	14.100	14.500	0.555	0.571
Phi		1.600		0.063
h	0.000	0.380	0.000	0.015



3-pin SOT89 Outline Dimensions

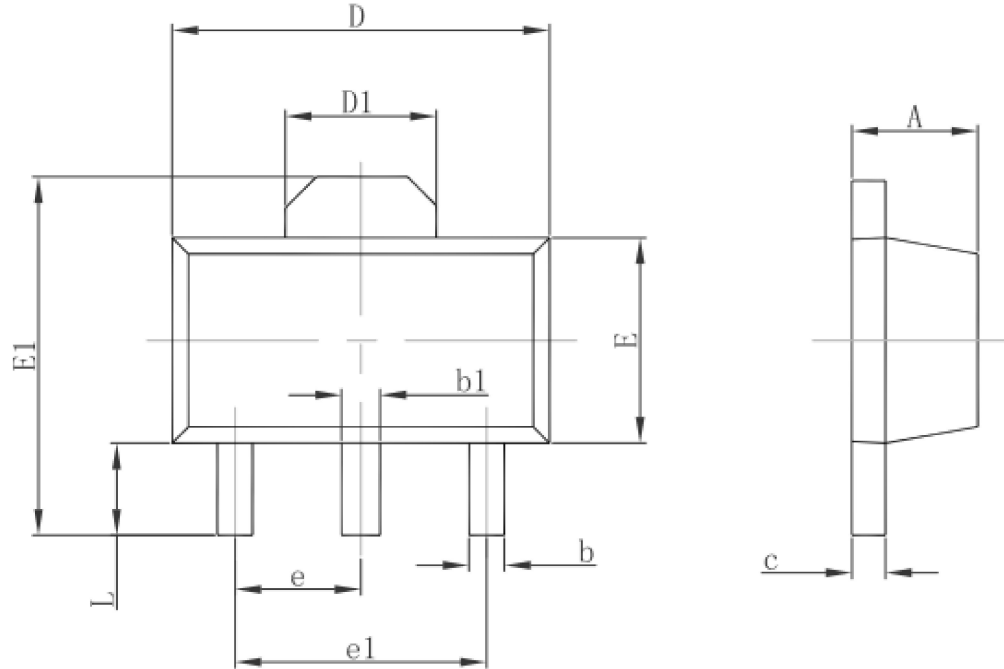

Symbol	Dimensions In Millimeters		Dimensions In Inches	
	Min.	Max.	Min.	Max.
A	1.400	1.600	0.055	0.063
b	0.320	0.520	0.013	0.020
b1	0.400	0.580	0.016	0.023
c	0.350	0.440	0.014	0.017
D	4.400	4.600	0.173	0.181
D1	1.550 REF.		0.061 REF.	
E	2.300	2.600	0.091	0.102
E1	3.940	4.250	0.155	0.167
e	1.500 TYP.		0.060 TYP.	
e1	3.000 TYP.		0.118 TYP.	
L	0.900	1.200	0.035	0.047



3-pin SOT23-3 Outline Dimensions

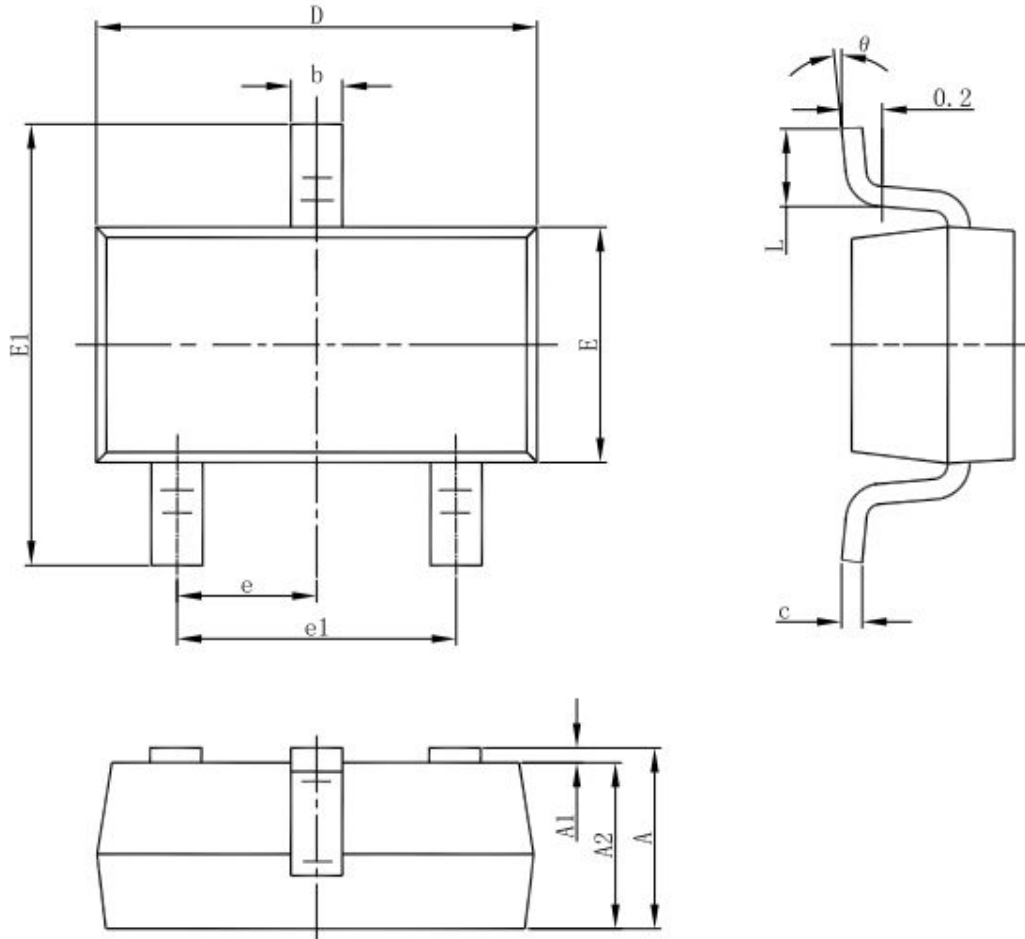

Symbol	Dimensions In Millimeters		Dimensions In Inches	
	Min	Max	Min	Max
A	1.050	1.250	0.041	0.049
A1	0.000	0.100	0.000	0.004
A2	1.050	1.150	0.041	0.045
b	0.300	0.500	0.012	0.020
c	0.100	0.200	0.004	0.008
D	2.820	3.020	0.111	0.119
E	1.500	1.700	0.059	0.067
E1	2.650	2.950	0.104	0.116
e	0.950(BSC)		0.037(BSC)	
e1	1.800	2.000	0.071	0.079
L	0.300	0.600	0.012	0.024
θ	0°	8°	0°	8°



3-pin SOT23 Outline Dimensions

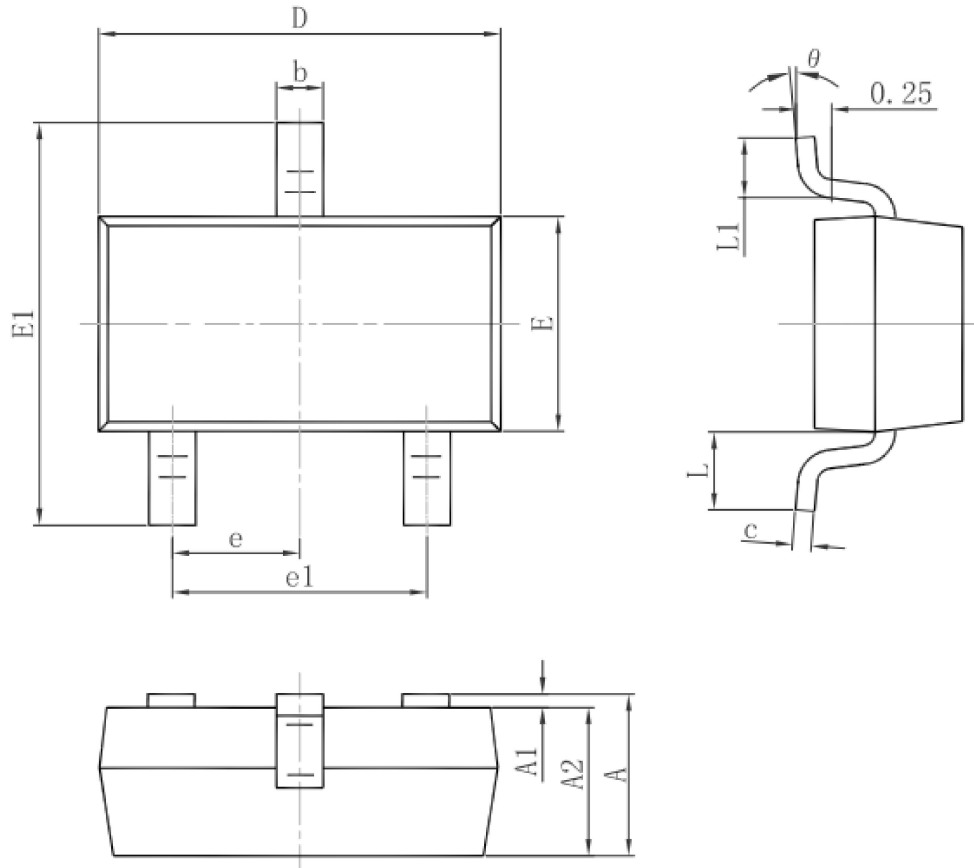

Symbol	Dimensions In Millimeters		Dimensions In Inches	
	Min.	Max.	Min.	Max.
A	0.900	1.150	0.035	0.045
A1	0.000	0.100	0.000	0.004
A2	0.900	1.050	0.035	0.041
b	0.300	0.500	0.012	0.020
c	0.080	0.150	0.003	0.006
D	2.800	3.000	0.110	0.118
E	1.200	1.400	0.047	0.055
E1	2.250	2.550	0.089	0.100
e	0.950 TYP.		0.037 TYP.	
e1	1.800	2.000	0.071	0.079
L	0.550 REF.		0.022 REF.	
L1	0.300	0.500	0.012	0.020
theta	0°	8°	0°	8°



Product Tape and Reel Specifications
3-pin TO92 Reel Dimensions (Unit: mm)

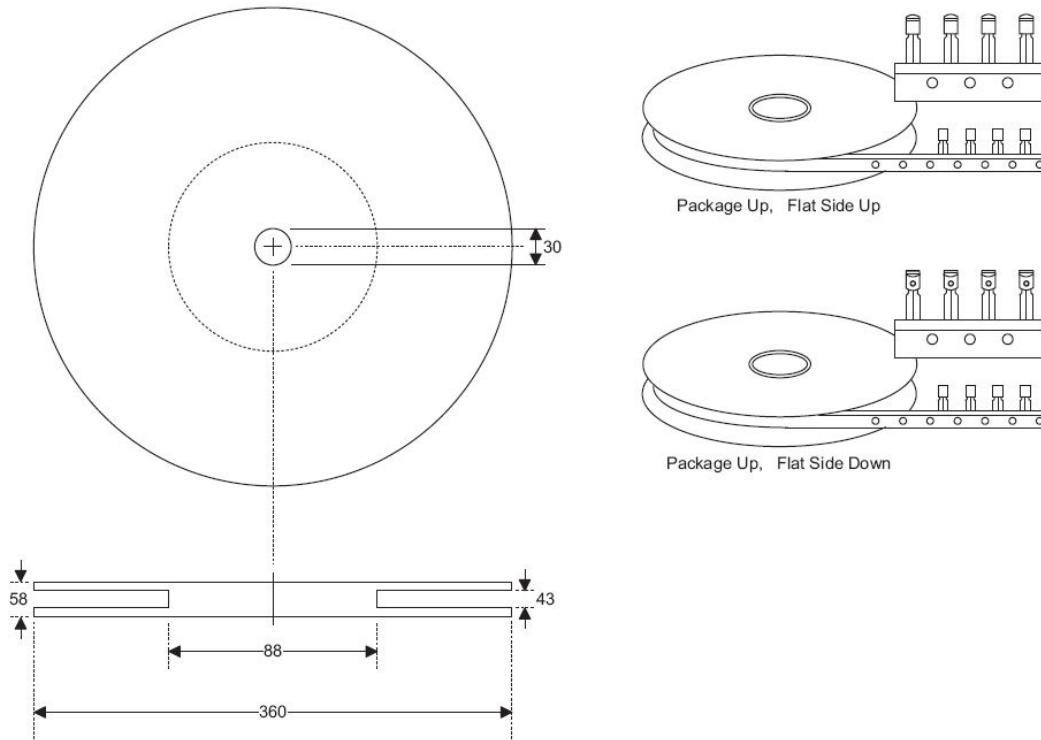

Reel Dimensions

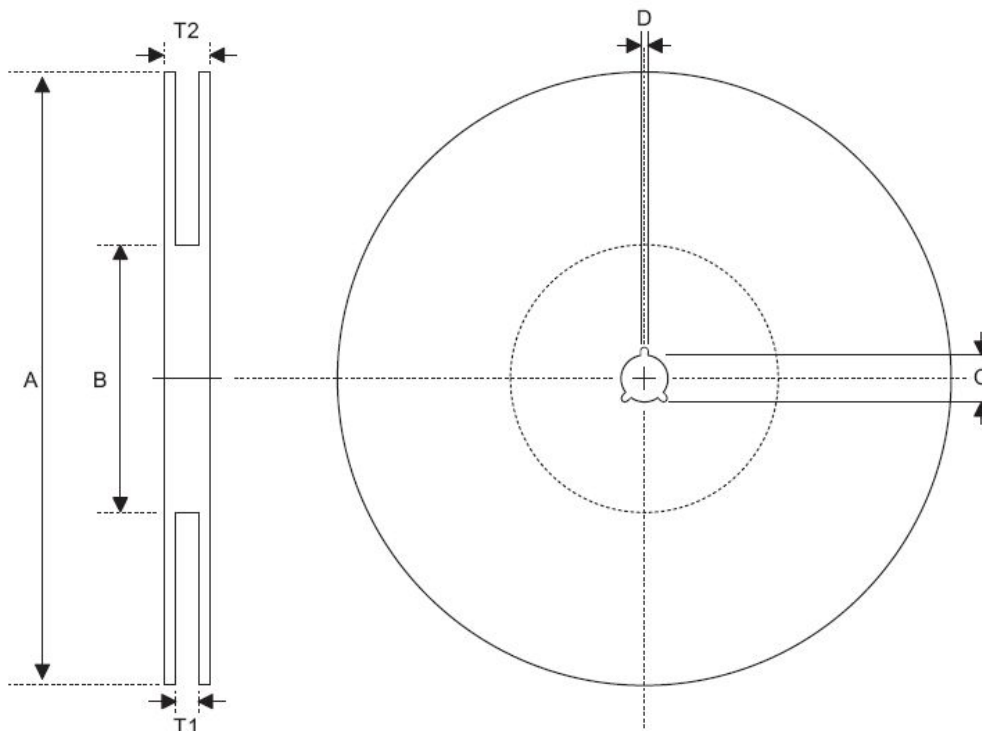



SOT89

Symbol	Description	Dimensions in mm
A	Reel Outer Diameter	180.0±1.0
B	Reel Inner Diameter	62.0±1.5
C	Spindle Hole Diameter	12.75 ^{+0.15/-0.00}
D	Key Slit Width	1.90±0.15
T1	Space Between Flange	12.4 ^{+0.2/-0.00}
T2	Reel Thickness	17.0 ^{+0.0/-0.4}



Carrier Tape Dimensions

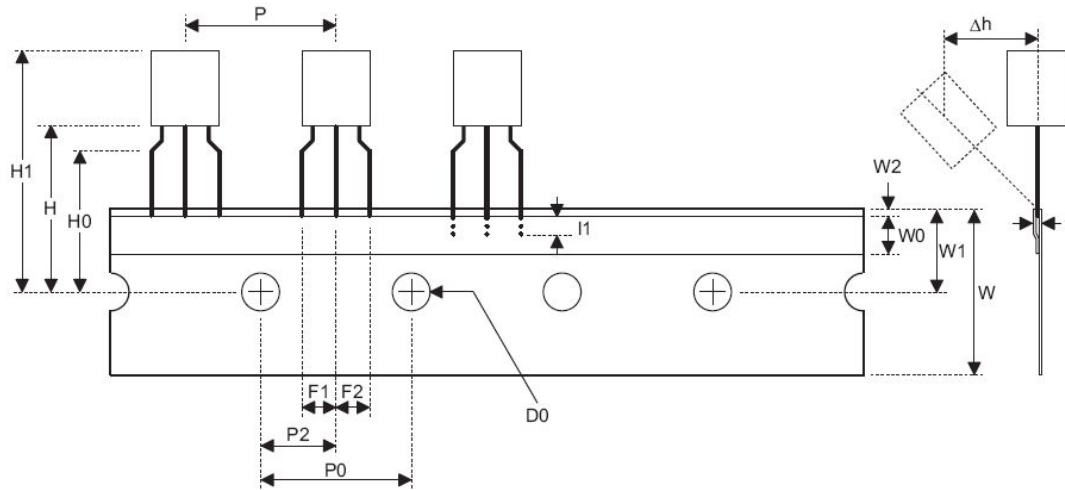

TO92

Symbol	Description	Dimensions in mm
I1	Taped Lead Length	(2.5)
P	Component Pitch	12.7±1.0
P ₀	Perforation Pitch	12.7±0.3
P ₂	Component to Perforation (Length Direction)	6.35±0.40
F ₁	Lead Spread	2.5 ^{+0.4/-0.1}
F ₂	Lead Spread	2.5 ^{+0.4/-0.1}
Δh	Component Alignment	0.0±0.1
W	Carrier Tape Width	18.0 ^{+1.0/-0.5}
W ₀	Hold-down Tape Width	6.0±0.5
W ₁	Perforation Position	9.0±0.5
W ₂	Hold-down Tape Position	(0.5)
H ₀	Lead Clinch Height	16.0±0.5
H ₁	Component Height	Less than 24.7
D ₀	Perforation Diameter	4.0±0.2
t	Taped Lead Thickness	0.7±0.2
H	Component Base Height	19.0±0.5

Note: Thickness less than 0.38_0.05mm~0.5mm

P0 Accumulated pitch tolerance: _1mm/20pitches.

() Bracketed figures are for consultation only



Carrier Tape Dimensions

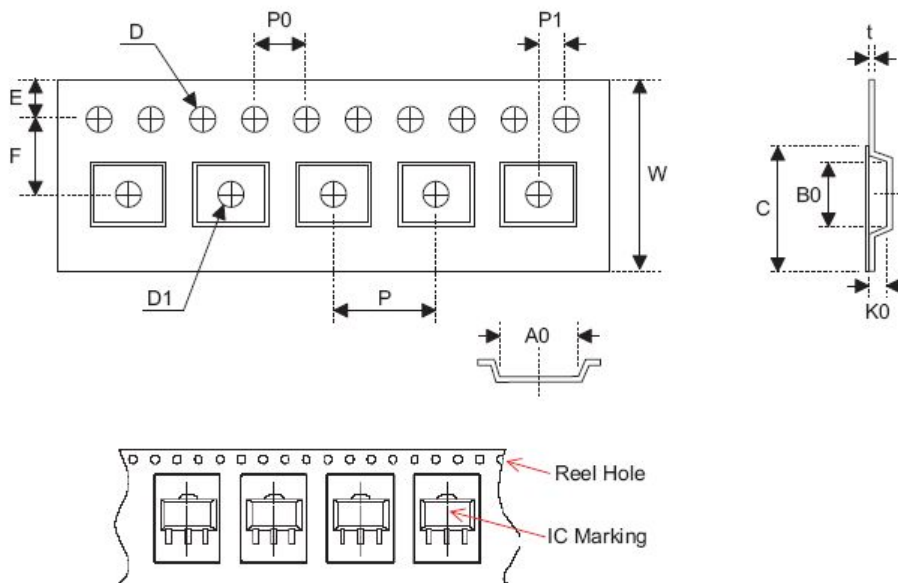

SOT89

Symbol	Description	Dimensions in mm
W	Carrier Tape Width	12.0 ^{+0.3/-0.1}
P	Cavity Pitch	8.0±0.1
E	Perforation Position	1.75±0.10
F	Cavity to Perforation (Width Direction)	5.50±0.05
D	Perforation Diameter	1.5 ^{+0.1/-0.0}
D1	Cavity Hole Diameter	1.5 ^{+0.1/-0.0}
P0	Perforation Pitch	4.0±0.1
P1	Cavity to Perforation (Length Direction)	2.0±0.1
A0	Cavity Length	4.8±0.1
B0	Cavity Width	4.5±0.1
K0	Cavity Depth	1.8±0.1
t	Carrier Tape Thickness	0.300±0.013
C	Cover Tape Width	9.3±0.1



CBC Microelectronics
<http://www.cbcv.net>

TX71XXM series
50mA Low Power LDO

IMPORTANT NOTICE

CBC Microelectronics Co;LTD reserves the right to make changes without further notice to any products or specifications herein. CBC Microelectronics Co;LTD does not assume any responsibility for use of any its products for any particular purpose, nor does CBC Microelectronics Co;LTD assume any liability arising out of the application or use of any its products or circuits. CBC Microelectronics Co;LTD does not convey any license under its patent rights or other rights nor the rights of others.