



### Features

- Low voltage drop: 0.06V@100mA
- High input voltage: 8.5V
- Low temperature coefficient
- Low Quiescent Current: 25uA at 5.0V
- Output voltage accuracy: tolerance  $\pm 2\%$
- SOT23-5 , SOT89 and SOT223 packages

### Applications

- Battery-powered equipment
- Hand-Hold Equipment
- GRS Receivers
- Wireless LAN

### General Description

The MB6250 series is a group of positive voltage output, three-pin regulators, that provide a high current even when the input/output voltage differential is small. Low power consumption and high accuracy is achieved through CMOS and laser trimming technologies.

The MB6250 consists of a high-precision voltage reference, an error amplification circuit, and a current limited output driver. Transient response to a load variations have improved in comparison to the existing series.

### Order Information

MB6250①②③④

Designator	Symbol	Description
①	P	Package:SOT89A
	PB	Package:SOT89B
	M5	Package:SOT23-5
	GB	Package:SOT223B
②③	Integer	Output Voltage(0.8~5.0V)
④	R	RoHS / Pb Free
	G	Halogen Free

### Block Diagram

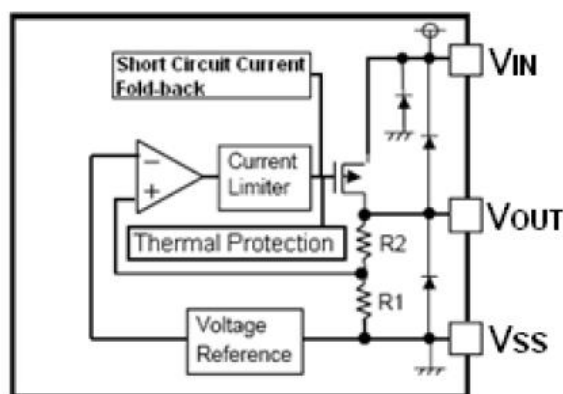



Pin Assignment

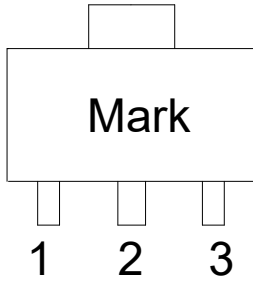

Table1 MB6250 series (SOT89A PKG)

PIN NO.	PIN NAME	FUNCTION
1	GND	GND pin
2	VIN	Input voltage pin
3	VOUT	Output voltage pin

Table2 MB6250 series (SOT89B PKG)

PIN NO.	PIN NAME	FUNCTION
1	VIN	Input voltage pin
2	GND	GND pin
3	VOUT	Output voltage pin

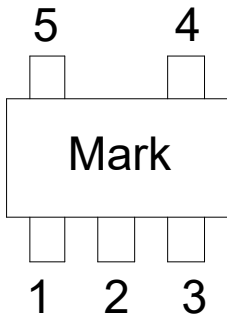

Table3 MB6250 series (SOT23-5 PKG)

PIN NO.	PIN NAME	FUNCTION
1	VIN	Input voltage pin
2	GND	GND pin
3	EN	Enable pin "H": Normal operation "L": Step-up stopped
4	NC	(N.C.)
5	VOUT	Output voltage pin

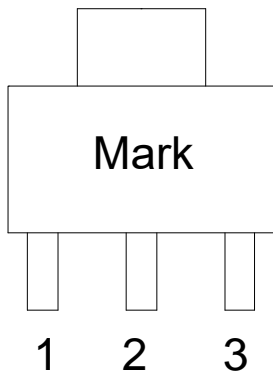

Table4 MB6250 series (SOT223B PKG)

PIN NO.	PIN NAME	FUNCTION
1	VIN	Input voltage pin
2	GND	GND pin
3	VOUT	Output voltage pin



1A Low Power High PSRR LDO

Marking Rule

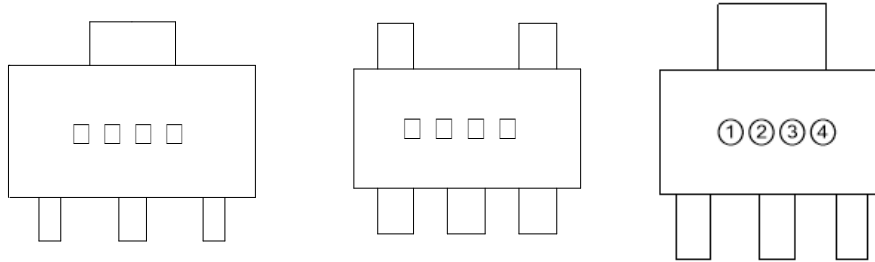

- ① product code: H
- ② output voltage code:

Voltage(V)	Code	Voltage(V)	Code	Voltage(V)	Code
0.6	m	2.1	7	3.6	L
0.7	n	2.2	8	3.7	M
0.8	h	2.3	9	3.8	N
0.9	k	2.4	0	3.9	O
1.0	a	2.5	A	4.0	P
1.1	b	2.6	B	4.1	Q
1.2	c	2.7	C	4.2	R
1.3	d	2.8	D	4.3	S
1.4	e	2.9	E	4.4	T
1.5	1	3.0	F	4.5	U
1.6	2	3.1	G	4.6	V
1.7	3	3.2	H	4.7	W
1.8	4	3.3	I	4.8	X
1.9	5	3.4	J	4.9	Y
2.0	6	3.5	K	5.0	Z

- ③ CE code

Symbol	Standard
E	With CE
N	Without CE

- ④ Data Code: X

**Absolute Maximum Ratings**

Supply Voltage .....-0.3V to 8.5V      Operating Temperature .....-40°C to 85°C  
 Output Current.....1.1A                      Storage Temperature .....-40°C to 125°C

Note: These are stress ratings only. Stresses exceeding the range specified under “Absolute Maximum Ratings” may cause substantial damage to the device. Functional operation of this device at other conditions beyond those listed in the specification is not implied and prolonged exposure to extreme conditions may affect device reliability.

**Electrical Characteristics**

MB6250 for any output voltage

(Ta=25°C)

Parameter	Symbol	Conditions	Min.	Typ.	Max.	Unit
Output Voltage	Vout	Vin=Vout+1V 1.0mA≤Iout≤30mA	Vout×0.98	--	Vout×1.02	V
Output Current*1	Iout	Vin-Vout=1V	--	1000	--	mA
Low dropout*2	Vdrop	Refer to the next table				
Line Regulation	$\Delta V_{out1}/(V_{in}-V_{out})$	1.6V≤Vin≤8V Iout=100mA	--	0.05	0.2	%/V
Load Regulation	$\Delta V_{out}$	Vin= Vout+1V 1.0mA≤Iout≤100mA	--	12	30	mV
Output voltage Temperature Coefficiency	$\Delta V_{out}/(T_a \cdot V_{out})$	Iout=30mA 0°C≤Ta≤70°C	--	±100	--	Ppm/°C
PSRR	PSRR	F=1KHz Vin=Vout+1V	--	70	--	dB
Supply Current	I <sub>SS</sub>	--	--	25	35	uA
Input Voltage	Vin	--	--	--	7.5	V
Thermal shutdown detection temperature	T <sub>SD</sub>	Junction temperature	-	160	-	°C
Thermal shutdown release temperature	T <sub>SR</sub>	Junction temperature	-	140	-	°C



### Electrical Characteristics by Output Voltage:

Output Voltage Vout(V)	Dropout Voltage Vdif (V)		
	Conditions	Typ.	Max.
$V_{out} \leq 2.0V$	$I_{out}=60\text{ mA}$	0.05	0.08
$2.0 < V_{out} \leq 3.0$	$I_{out}=80\text{ mA}$	0.05	0.08
$3.0 < V_{out} \leq 4.0$	$I_{out}=100\text{ mA}$	0.06	0.08
$4.0 < V_{out} \leq 5.0$		0.05	0.08
$3.0 < V_{out} \leq 4.0$	$I_{out}=200\text{ mA}$	0.13	0.16
$4.0 < V_{out} \leq 5.0$		0.12	0.16
$3.0 < V_{out} \leq 4.0$	$I_{out}=1000\text{ mA}$	0.65	0.8
$4.0 < V_{out} \leq 5.0$		0.6	0.8

### Application Circuits

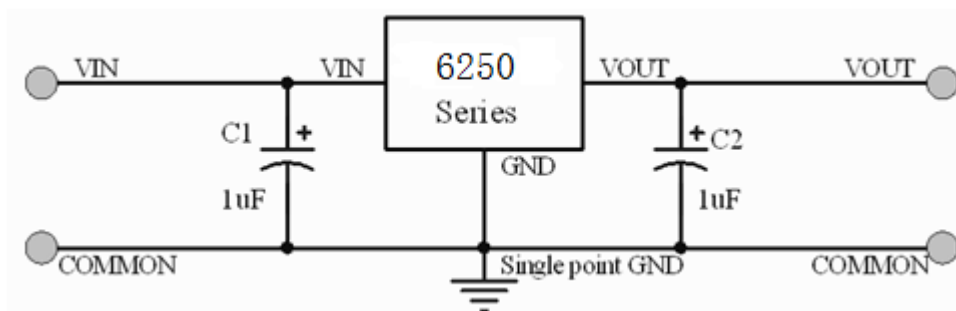

Note1: Input capacitor  $C_{IN}=1\mu F$ .

Note2: Output capacitor  $C_{OUT}=1\mu F/6.8\mu F$  (1uF Tantalum capacitor or 6.8uF ceramic capacitor is recommended).

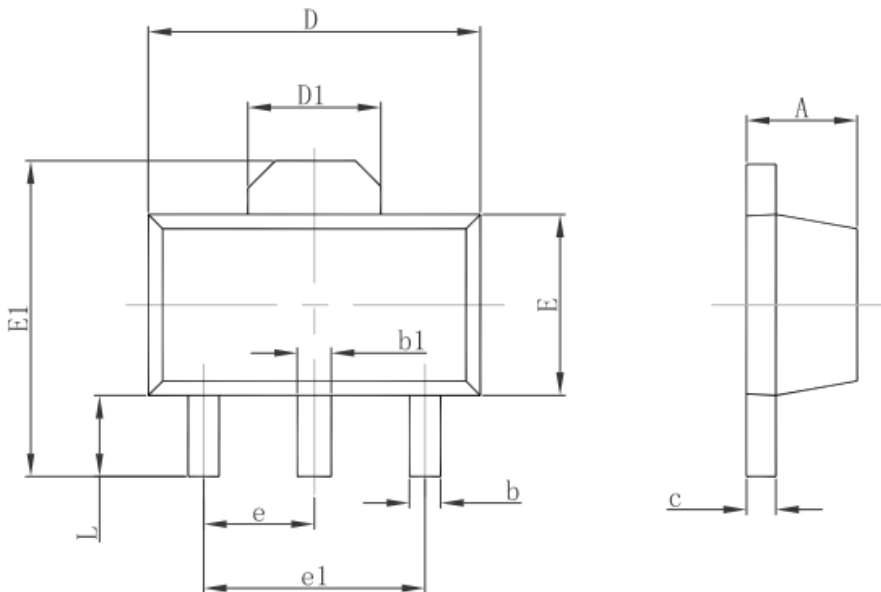
**Package Information****SOT-89-3L PACKAGE OUTLINE DIMENSIONS**

Symbol	Dimensions In Millimeters		Dimensions In Inches	
	Min.	Max.	Min.	Max.
A	1.400	1.600	0.055	0.063
b	0.320	0.520	0.013	0.020
b1	0.400	0.580	0.016	0.023
c	0.350	0.440	0.014	0.017
D	4.400	4.600	0.173	0.181
D1	1.550 REF.		0.061 REF.	
E	2.300	2.600	0.091	0.102
E1	3.940	4.250	0.155	0.167
e	1.500 TYP.		0.060 TYP.	
e1	3.000 TYP.		0.118 TYP.	
L	0.900	1.200	0.035	0.047



**SOT23-5 Outline Dimensions**

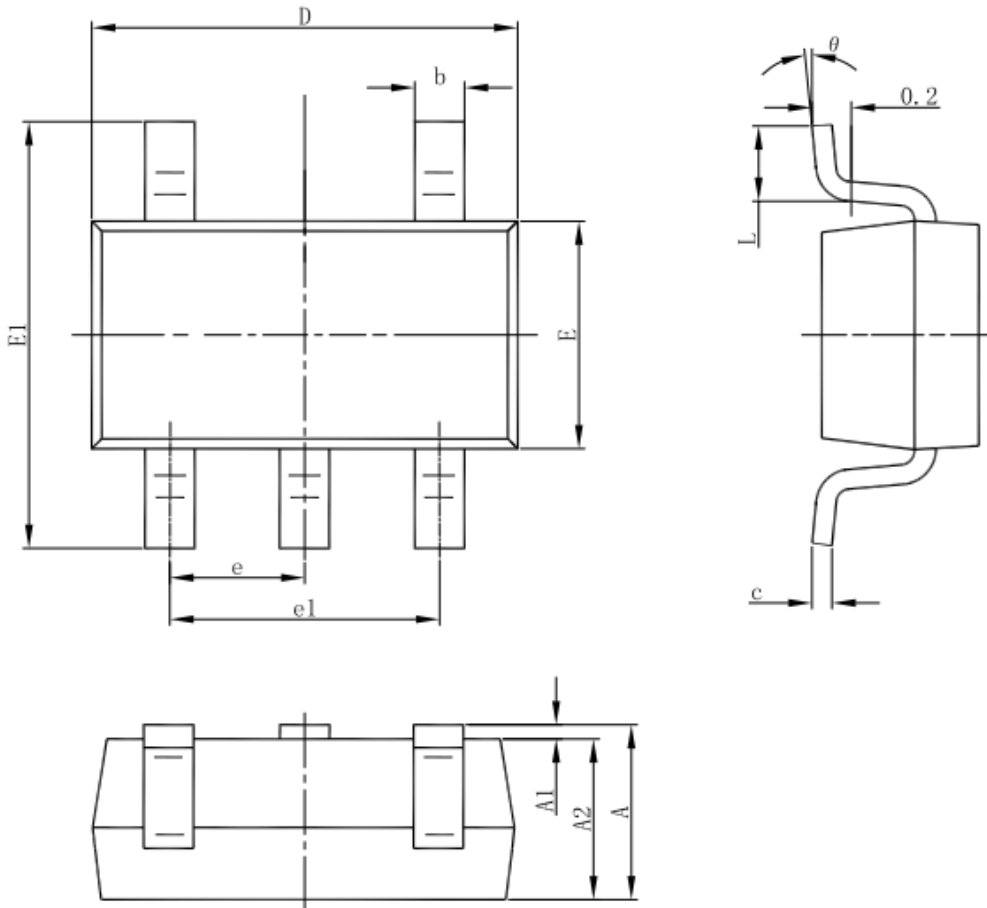

Symbol	Dimensions In Millimeters		Dimensions In Inches	
	Min	Max	Min	Max
A	1.050	1.250	0.041	0.049
A1	0.000	0.100	0.000	0.004
A2	1.050	1.150	0.041	0.045
b	0.300	0.500	0.012	0.020
c	0.100	0.200	0.004	0.008
D	2.820	3.020	0.111	0.119
E	1.500	1.700	0.059	0.067
E1	2.650	2.950	0.104	0.116
e	0.950(BSC)		0.037(BSC)	
e1	1.800	2.000	0.071	0.079
L	0.300	0.600	0.012	0.024
θ	0°	8°	0°	8°



**SOT-223 PACKAGE OUTLINE DIMENSIONS**

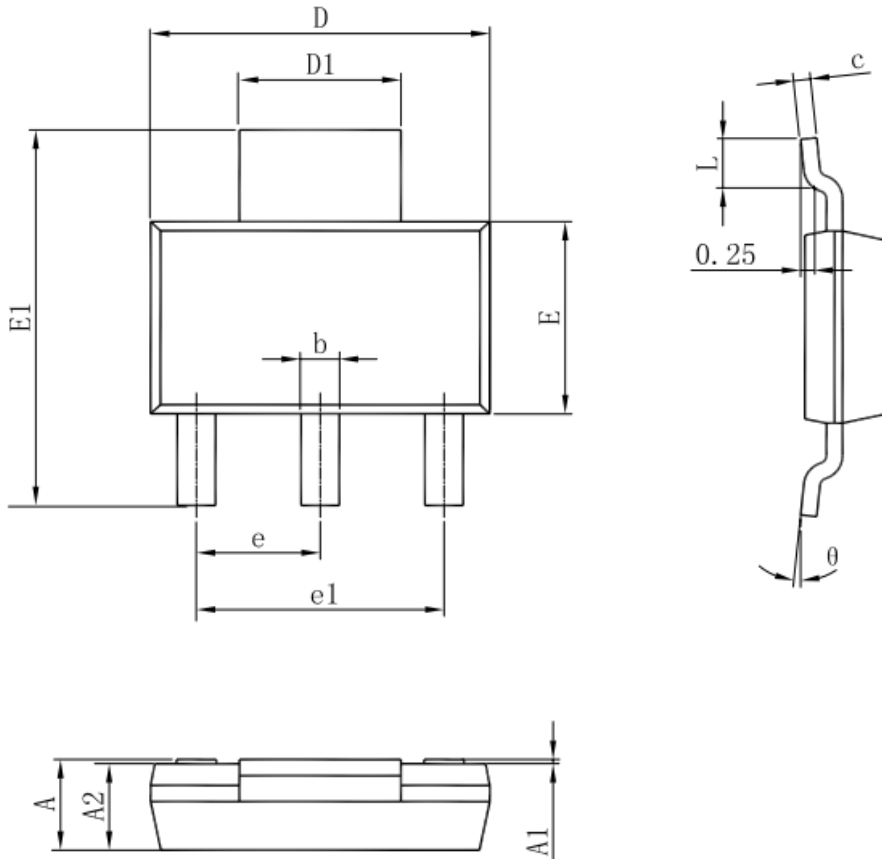

Symbol	Dimensions In Millimeters		Dimensions In Inches	
	Min	Max	Min	Max
A	1.520	1.800	0.060	0.071
A1	0.000	0.100	0.000	0.004
A2	1.500	1.700	0.059	0.067
b	0.660	0.820	0.026	0.032
c	0.250	0.350	0.010	0.014
D	6.200	6.400	0.244	0.252
D1	2.900	3.100	0.114	0.122
E	3.300	3.700	0.130	0.146
E1	6.830	7.070	0.269	0.278
e	2.300(BSC)		0.091(BSC)	
e1	4.500	4.700	0.177	0.185
L	0.900	1.150	0.035	0.045
θ	0°	10°	0°	10°



***CBC Microelectronics Co.,Ltd***

*<http://www.cbcv.net>*

**IMPORTANT NOTICE**

CBC Microelectronics Co., Ltd reserves the right to make modifications, enhancements, improvements, corrections or other changes without further notice to this document and any product described herein or to discontinue any product or service. Customers should obtain the latest relevant information before placing orders and should verify the latest and complete information. CBC Microelectronics does not assume any responsibility for use of any product, nor does CBC Microelectronics any liability arising out of the application or use of this document or any product or circuit described herein. CBC Microelectronics assumes no liability for applications assistance or the design of Customers' products. Customers are responsible for their products and applications using CBC Microelectronics components. CBC Microelectronics does not convey any license under its patent or trademark rights nor the other rights.

CBC Microelectronics Co., Ltd © 2004-2021.