



### Features

- Low voltage drop: 0.17V@100mA
- High input voltage: 15V
- Low temperature coefficient
- Large Output Current: >0.5A
- Low Quiescent Current: 2.0uA
- Output voltage accuracy: tolerance  $\pm 2\%$
- Built-in current limiter
- SOT89,SOT89-5,SOT23-3 and SOT23-5 packages

### Applications

- Battery-powered equipment
- Hand-Hold Equipment
- GRS Receivers
- Wireless LAN

### General Description

The MB72XXM series is a group of positive voltage output, three-pin regulators, it provide a high current even when the input/output voltage differential is small. Low power consumption and high accuracy is achieved through CMOS and laser trimming technologies.

The MB72XXM consists of a high-precision voltage reference, an error amplification circuit, and a current limited output driver. Load Transient response has improved in comparison to the existing series. SOT89, SOT89-5,SOT23-3 and SOT23-5 packages are available.

### Selection Table

Part No.	Output Voltage	Package	Marking
MB7218Mxx	1.8V	SOT89 SOT89-5 SOT23-3 SOT23-5	Refer to Marking rule
MB7228Mxx	2.8V		
MB7230Mxx	3.0V		
MB7233Mxx	3.3V		
MB7236Mxx	3.6V		
MB7240Mxx	4.0V		
MB7245Mxx	4.5V		
MB7250Mxx	5.0V		

### Order Information

MB72①②③④⑤

Designator	Symbol	Description
① ②	Integer	Output Voltage(1.8~5.0V)
③	M	Standard
④	P	Package:SOT89
	P5	Package:SOT89-5
	M	Package:SOT23-3
	M5	Package:SOT23-5
	M5B	Package:SOT23-5B
⑤	R	RoHS / Pb Free
	G	Halogen Free

Note: "①②" stands for output voltages. Other voltages can be specially customized



### Block Diagram

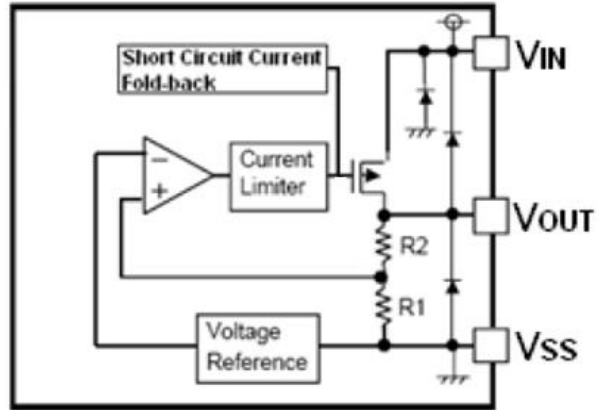



### Pin Assignment

SOT23-3 (Top View)

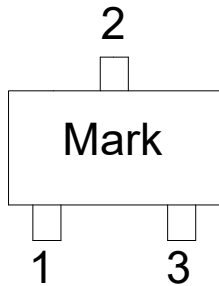

Table1: MB72XXMMR series (SOT23-3 PKG)

PIN NO.	PIN NAME	FUNCTION
1	GND	GND pin
2	VIN	Input voltage pin
3	VOUT	Output voltage pin

SOT23-5 (Top View)

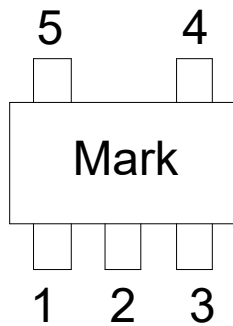

Table2: MB72XXMM5R/MB72XXMM5BR series (SOT23-5 PKG)

PIN NO.		PIN NAME	FUNCTION
SOT23-5	Sot23-5B		
1	2	VIN	Input voltage pin
2	1	GND	GND pin
3	3	CE	Enable pin
4	4	NC	--
5	5	VOUT	Output voltage pin

SOT89 (Top View)

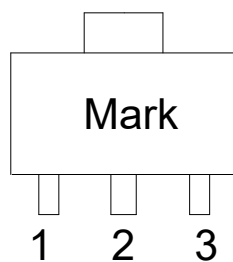

Table3: MB72XXMPR series (SOT89 PKG)

PIN NO.	PIN NAME	FUNCTION
1	GND	GND pin
2	VIN	Input voltage pin
3	VOUT	Output voltage pin

SOT89-5 (Top View)

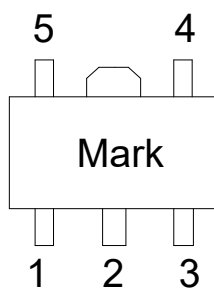

Table4: MB72XXMP5R series (SOT89-5 PKG)

PIN NO.	PIN NAME	FUNCTION
1	CE	Enable pin
2	VIN	Input voltage pin
3	NC	--
4	GND	GND pin
5	VOUT	Output voltage pin



### Marking Rule

#### (1) SOT23-3 and SOT23-5

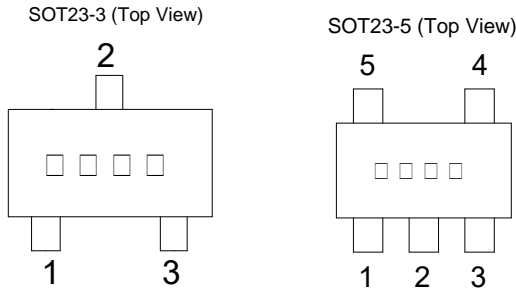

List of Product Name vs. Product Code

Product Name	Product Code		
	(1)	(2)	(3)
MB7212	S	A	A
MB7213	S	A	B
MB7214	S	A	C
MB7215	S	A	D
MB7216	S	A	E
MB7217	S	A	F
MB7218	S	A	G
MB7219	S	A	I
MB7220	S	A	J
MB7221	S	A	K
MB7222	S	A	L
MB7223	S	A	M
MB7224	S	A	N
MB7225	S	A	O
MB7226	S	A	P
MB7227	S	A	Q
MB7228	S	A	R
MB7229	S	A	T
MB7230	S	A	U
MB7231	S	A	V

Product Name	Product Code		
	(1)	(2)	(3)
MB7232	S	A	W
MB7233	S	A	X
MB7234	S	A	Y
MB7235	S	A	Z
MB7236	S	B	A
MB7237	S	B	B
MB7238	S	B	C
MB7239	S	B	D
MB7240	S	B	E
MB7241	S	B	F
MB7242	S	B	J
MB7243	S	B	H
MB7244	S	B	I
MB7245	S	B	J
MB7246	S	B	K
MB7247	S	B	L
MB7248	S	B	M
MB7249	S	B	N
MB7250	S	B	O

**NOTE:** SOT23-5,the last is Z SOT23-5B,the last is Y



### (2) SOT89 and SOT89-5

SOT89 (Top View)

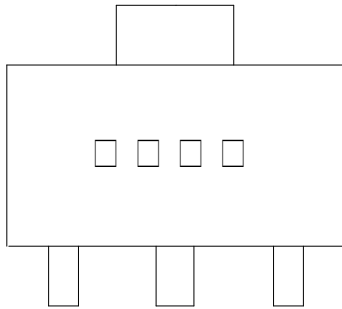

SOT89-5 (Top View)

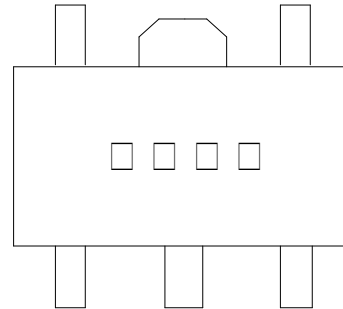

Product Code: E

Output Voltage Code:

Vout	Code	Vout	Code	Vout	Code
1.5V	1	2.7V	C	3.9V	O
1.6V	2	2.8V	D	4.0V	P
1.7V	3	2.9V	E	4.1V	Q
1.8V	4	3.0V	F	4.2V	R
1.9V	5	3.1V	G	4.3V	S
2.0V	6	3.2V	H	4.4V	T
2.1V	7	3.3V	I	4.5V	U
2.2V	8	3.4V	J	4.6V	V
2.3V	9	3.5V	K	4.7V	W
2.4V	0	3.6V	L	4.8V	X
2.5V	A	3.7V	M	4.9V	Y
2.6V	B	3.8V	N	5.0V	Z

Data Code:XX

Note: The last two of them are based on the time of this product which is the first time into production, and the third is the launch of this product ,it can be in 1 ~ 9 , which is expressed in "0" in October, in November with an "A", in December with "B"; the fourth is of the launch of the product, such as expressed in "0" in 2010, in "3" in 2013. For example: EZ81 represents MB7250PR product is first put into production in August in 2011.



### Absolute Maximum Ratings

Supply Voltage .....3.5V to 18V      Storage Temperature .....-40°C to 125°C  
 Operating Temperature .....-40°C to 85°C

Note: These are stress ratings only. Stresses exceeding the range specified under "Absolute Maximum Ratings" may cause substantial damage to the device. Functional operation of this device at other conditions beyond those listed in the specification is not implied and prolonged exposure to extreme conditions may affect device reliability.

### Electrical Characteristics

MB72XXM for any output voltage

(Ta=25°C)

Parameter	Symbol	Conditions	Min.	Typ.	Max.	Unit
Output Voltage	Vout	Vin=Vout+1V 1.0mA≤Iout≤30mA	Vout×0.98	--	Vout×1.02	V
Output Current*1	Iout	Vin-Vout=1V	--	500	--	mA
Low dropout*2	Vdrop	Refer to the next table				
Line Regulation	$\frac{\Delta V_{OUT}}{\Delta V_{IN} \times V_{OUT}}$	1.6V≤Vin≤8V Iout=100mA	--	0.05	0.2	%/V
Load Regulation	ΔVout	Vin= Vout+1V 1.0mA≤Iout≤100mA	--	12	30	mV
Output voltage Temperature Coefficiency	$\frac{\Delta V_{OUT}}{\Delta Ta}$	Iout=30mA 0°C≤Ta≤70°C	--	±100	--	Ppm/°C
PSRR	PSRR	F=1KHz Vin=Vout+1V	--	40	--	dB
Supply Current	Iss1	--	--	1	2	uA
Input Voltage	Vin	--	3.5	--	15	V

### Electrical Characteristics by Output Voltage:

Output Voltage Vout(V)	Dropout Voltage Vdif (V)		
	Conditions	Typ.	Max.
Vout ≤ 2.0V	Iout=60 mA	0.1	0.12
2.0 < Vout ≤ 3.0	Iout=80 mA	0.12	0.14
3.0 < Vout ≤ 4.0	Iout=100 mA	0.16	0.18
4.0 < Vout ≤ 5.0		0.17	0.18
3.0 < Vout ≤ 4.0	Iout=200 mA	0.21	0.24
4.0 < Vout ≤ 6.0		0.20	0.22
3.0 < Vout ≤ 4.0	Iout=500 mA	0.8	0.85
4.0 < Vout ≤ 6.0		0.75	0.80



### Typical Application

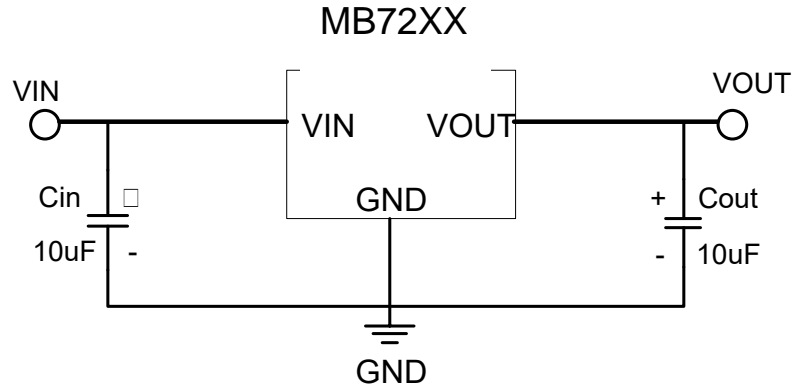

Note1:  $C_{in}=C_{out}=10\mu F$ . (10uF Electrolytic capacitor is recommended).

Note2: If the input and output capacitors are ceramic, add a resistor at the input, as follows.

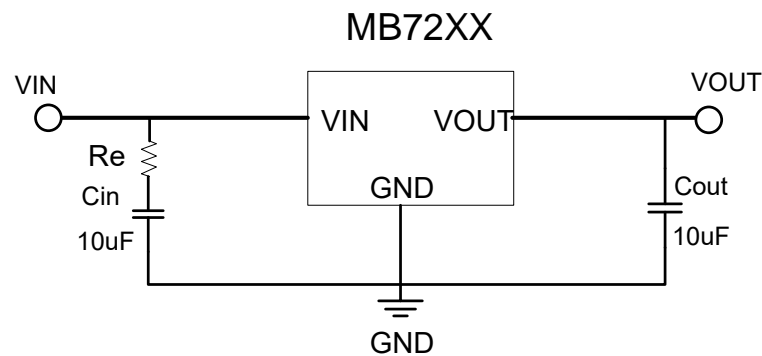

Note:  $R_e = (1.2 \sim 1.8) \Omega$ .

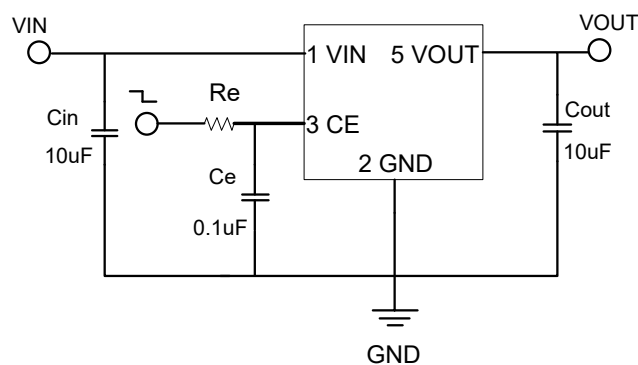

Note1: Input capacitor  $C_{IN}=10\mu F$ .

Note2: Output capacitor  $C_{OUT}=10\mu F/6.8\mu F$  (1uF Tantalum capacitor or 6.8uF ceramic capacitor is recommended).

Note3: The CE port is recommended to connect the current limiting resistor  $R_e$ . The recommended resistance is 10K~47K. When the input voltage is larger than or equal to 12V, it is recommended to add a 0.01uF capacitor  $C_e$ .



### Typical Performance Characteristics

#### (1) Output Voltage vs Input voltage

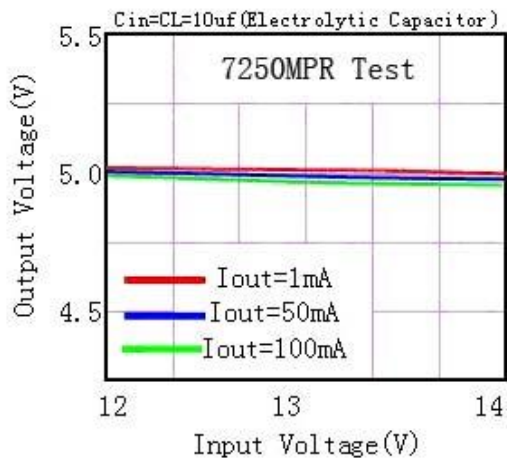
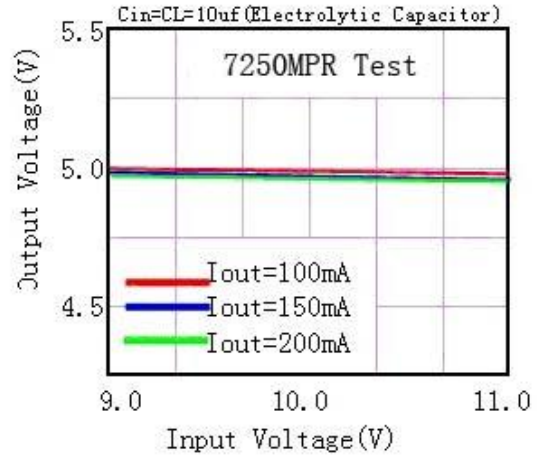
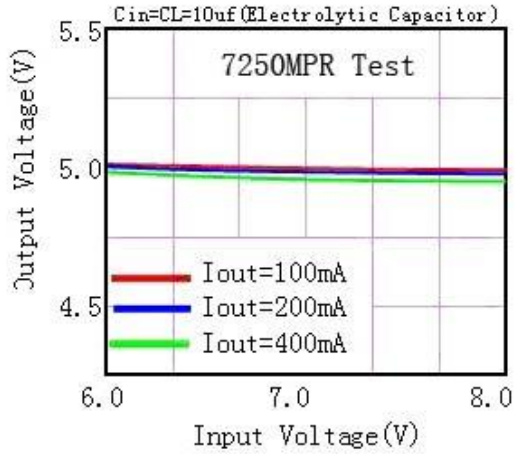





### (2) Output Voltage vs. Output Current

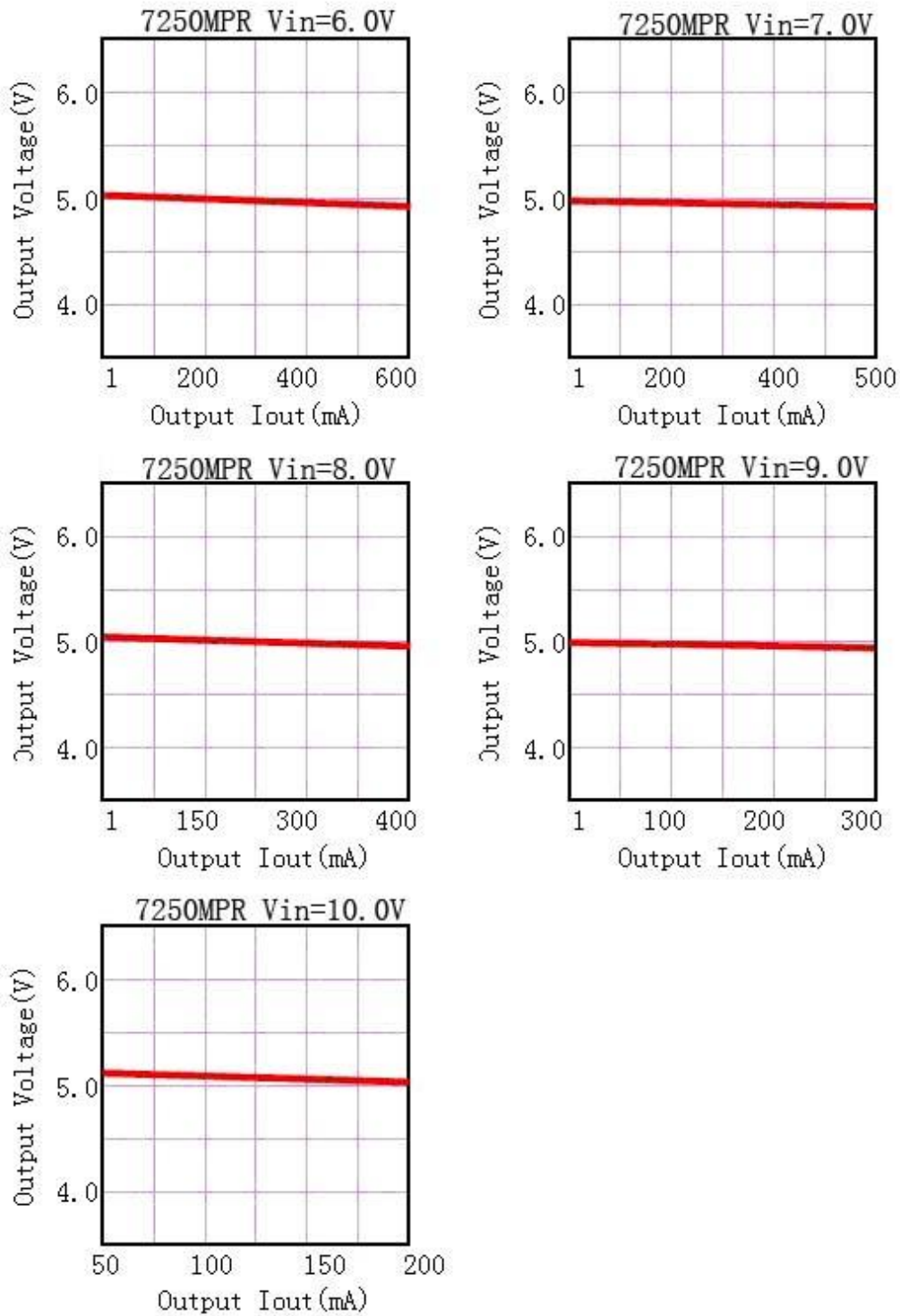



### (3) Output Voltage vs. Ambient Temperature

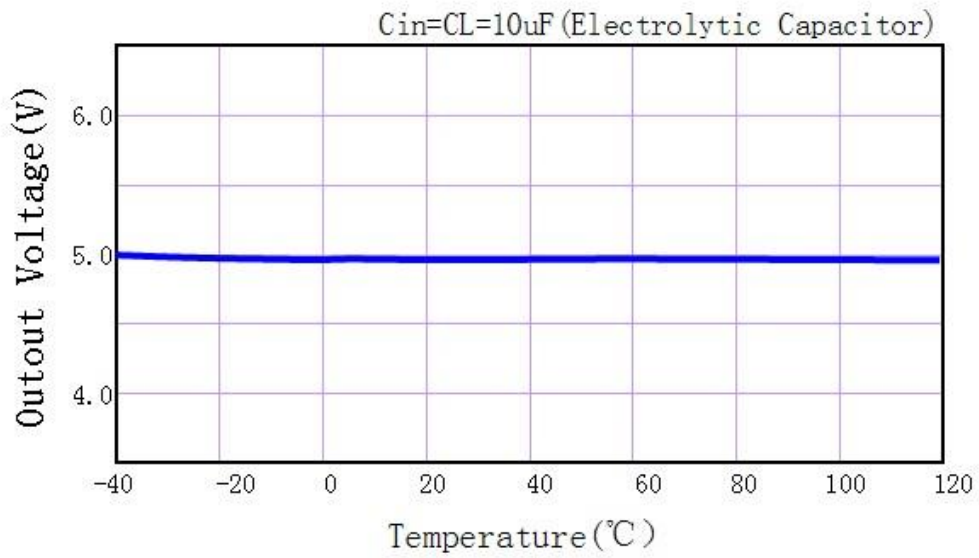



### Package Information 3-pin SOT89 Outline Dimensions

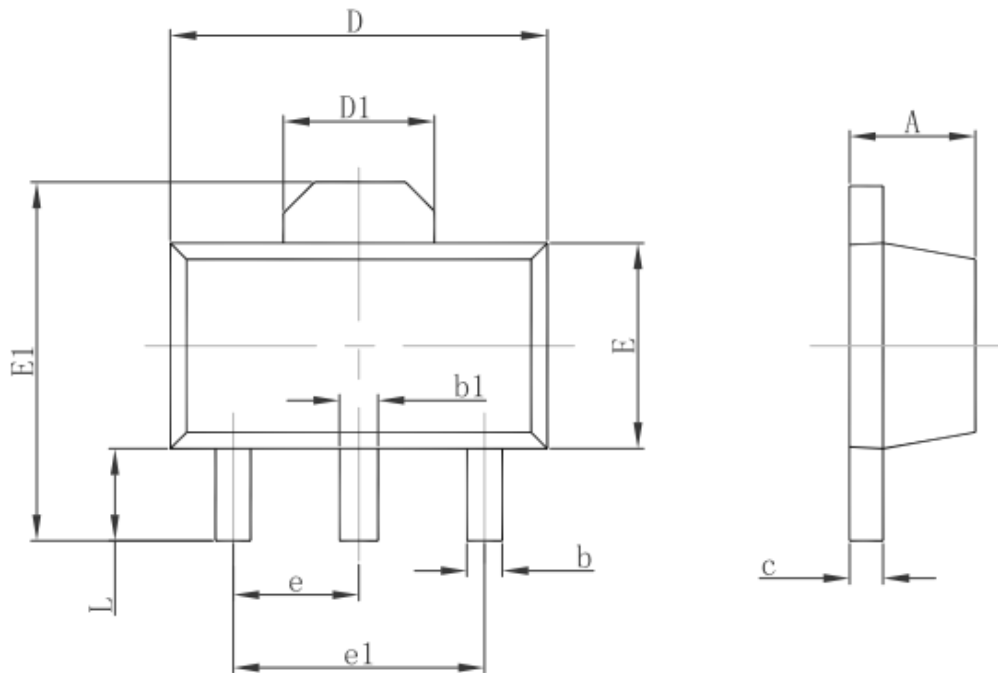

Symbol	Dimensions In Millimeters		Dimensions In Inches	
	Min.	Max.	Min.	Max.
A	1.400	1.600	0.055	0.063
b	0.320	0.520	0.013	0.020
b1	0.400	0.580	0.016	0.023
c	0.350	0.440	0.014	0.017
D	4.400	4.600	0.173	0.181
D1	1.550 REF.		0.061 REF.	
E	2.300	2.600	0.091	0.102
E1	3.940	4.250	0.155	0.167
e	1.500 TYP.		0.060 TYP.	
e1	3.000 TYP.		0.118 TYP.	
L	0.900	1.200	0.035	0.047



### SOT89-5 Outline Dimensions

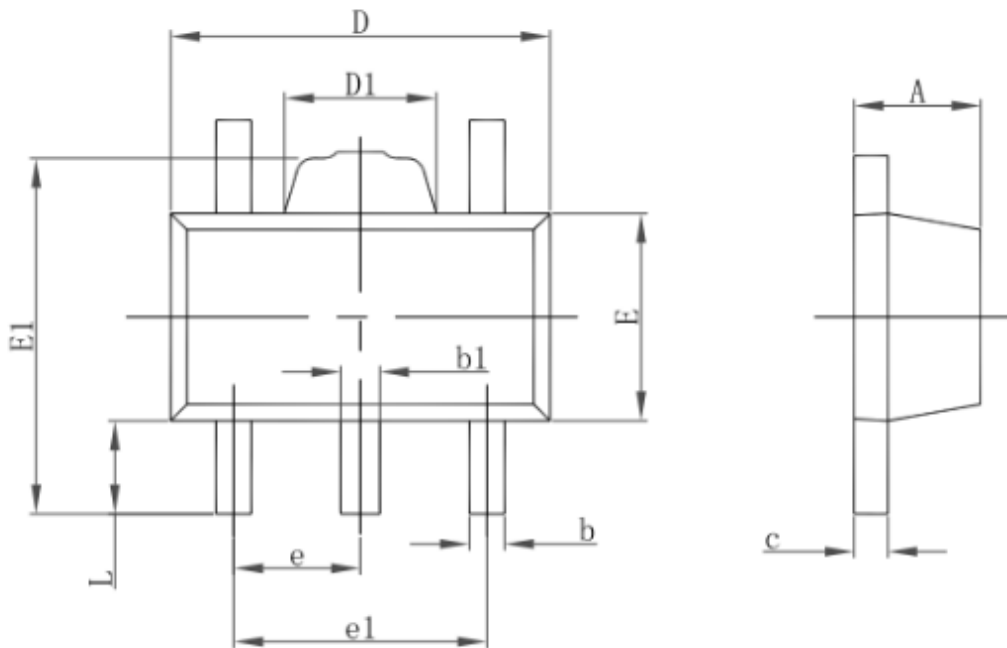

Symbol	Dimensions In Millimeters		Dimensions In Inches	
	Min.	Max.	Min.	Max.
A	1.400	1.600	0.055	0.063
b	0.320	0.520	0.013	0.020
b1	0.360	0.560	0.014	0.022
c	0.350	0.440	0.014	0.017
D	4.400	4.600	0.173	0.181
D1	1.400	1.800	0.055	0.071
E	2.300	2.600	0.091	0.102
E1	3.940	4.250	0.155	0.167
e	1.500TYP.		0.060TYP.	
e1	2.900	3.100	0.114	0.122
L	0.900	1.100	0.035	0.043



### 3-pin SOT23-3 Outline Dimensions

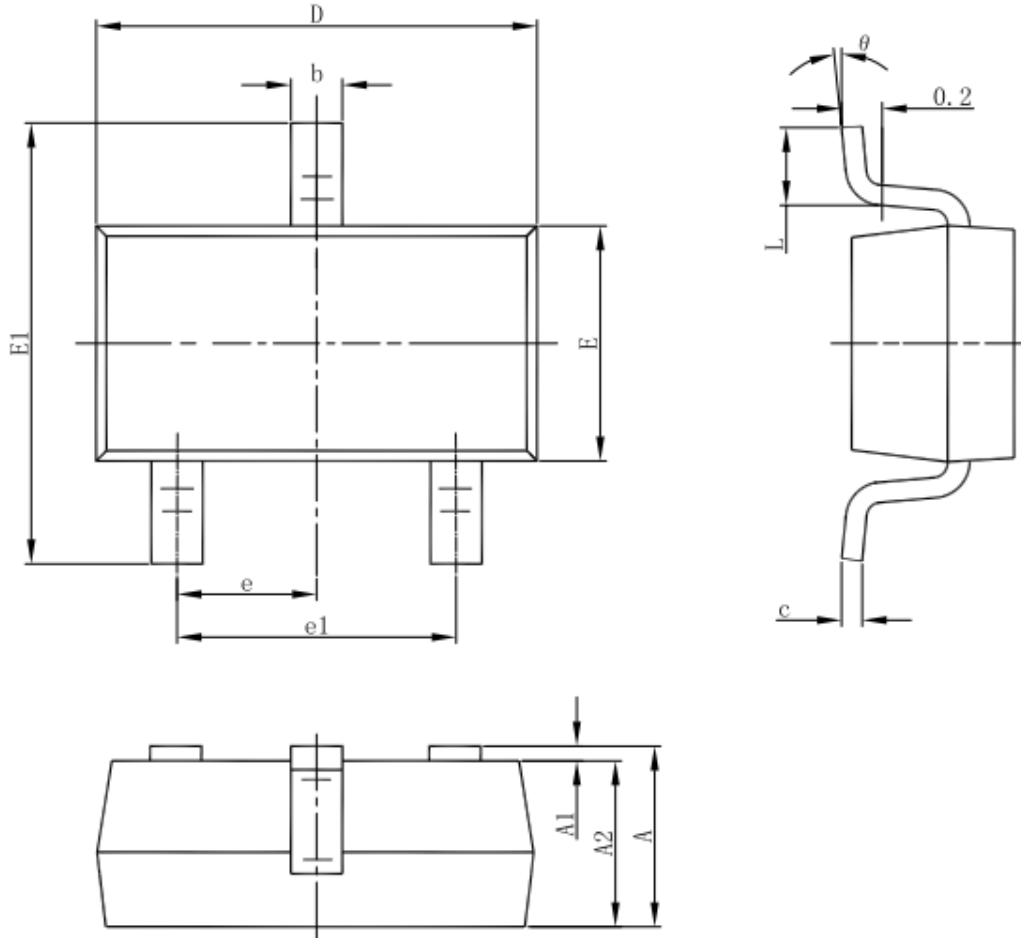

Symbol	Dimensions In Millimeters		Dimensions In Inches	
	Min	Max	Min	Max
A	1.050	1.250	0.041	0.049
A1	0.000	0.100	0.000	0.004
A2	1.050	1.150	0.041	0.045
b	0.300	0.500	0.012	0.020
c	0.100	0.200	0.004	0.008
D	2.820	3.020	0.111	0.119
E	1.500	1.700	0.059	0.067
E1	2.650	2.950	0.104	0.116
e	0.950(BSC)		0.037(BSC)	
e1	1.800	2.000	0.071	0.079
L	0.300	0.600	0.012	0.024
θ	0°	8°	0°	8°



### SOT23-5 Outline Dimensions

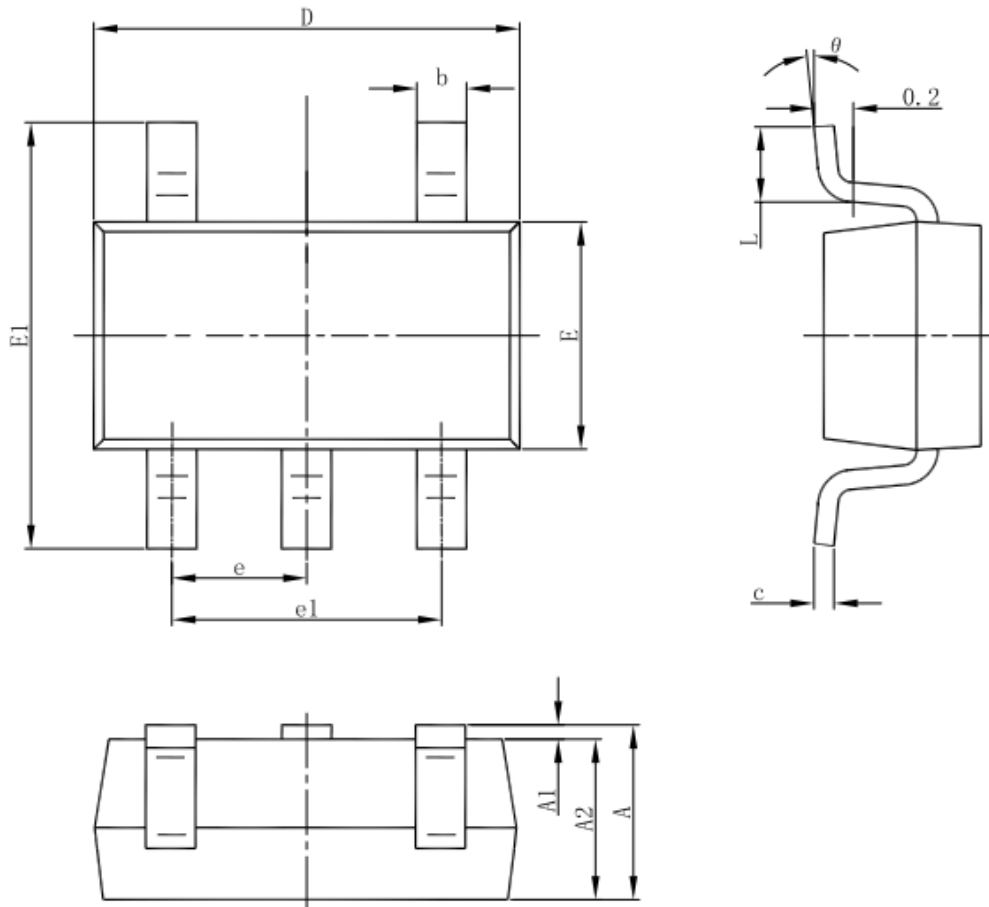

Symbol	Dimensions In Millimeters		Dimensions In Inches	
	Min	Max	Min	Max
A	1.050	1.250	0.041	0.049
A1	0.000	0.100	0.000	0.004
A2	1.050	1.150	0.041	0.045
b	0.300	0.500	0.012	0.020
c	0.100	0.200	0.004	0.008
D	2.820	3.020	0.111	0.119
E	1.500	1.700	0.059	0.067
E1	2.650	2.950	0.104	0.116
e	0.950(BSC)		0.037(BSC)	
e1	1.800	2.000	0.071	0.079
L	0.300	0.600	0.012	0.024
theta	0°	8°	0°	8°



# ***CBC Microelectronics Co.,Ltd***

*<http://www.cbcv.net>*

### **IMPORTANT NOTICE**

CBC Microelectronics Co., Ltd reserves the right to make modifications, enhancements, improvements, corrections or other changes without further notice to this document and any product described herein or to discontinue any product or service. Customers should obtain the latest relevant information before placing orders and should verify the latest and complete information. CBC Microelectronics does not assume any responsibility for use of any product, nor does CBC Microelectronics any liability arising out of the application or use of this document or any product or circuit described herein. CBC Microelectronics assumes no liability for applications assistance or the design of Customers' products. Customers are responsible for their products and applications using CBC Microelectronics components. CBC Microelectronics does not convey any license under its patent or trademark rights nor the other rights.

CBC Microelectronics Co., Ltd © 2004-2021.