



### Features

- Single-Supply Operation from +2.1V ~ +5.5V
- Rail-to-Rail Input / Output
- Gain-Bandwidth Product: 1MHz (Typ)
- Low Input Bias Current: 1pA (Typ)
- Low Offset Voltage: 3.5mV (Max)
- Quiescent Current: 40µA per Amplifier (Typ)
- Operating Temperature: -40°C ~ +125°C
- Embedded RF Anti-EMI Filter
- Small Package:
  - MA321 Available in SOT23-5 and SC70-5 Packages
  - MA358 Available in SOP-8, MSOP-8, DIP-8 and DFN-8 Packages
  - MA324 Available in SOP-14 and TSSOP-14 Packages

### General Description

The MA321/358/324 family have a high gain-bandwidth product of 1MHz, a slew rate of 0.6V/µs, and a quiescent current of 40µA /amplifier at 5V. The MA321/358/324 family is designed to provide optimal performance in low voltage and low noise systems. They provide rail-to-rail output swing into heavy loads. The input common mode voltage range includes ground, and the maximum input offset voltage is 3.5mV for MA321/358/324 family. They are specified over the extended industrial temperature range (-40°C to +125°C). The operating range is from 2.1V to 5.5V. The MA321 single is available in Green SC70-5 and SOT-23-5 packages. The MA358 Dual is available in Green SOP-8, MSOP-8, DIP-8 and DFN-8 packages. The MA324 Quad is available in Green SOP-14 and TSSOP-14 packages.

### Applications

- ASIC Input or Output Amplifier
- Sensor Interface
- Medical Communication
- Smoke Detectors
- Audio Output
- Piezoelectric Transducer Amplifier
- Medical Instrumentation
- Portable Systems

### Pin Configuration

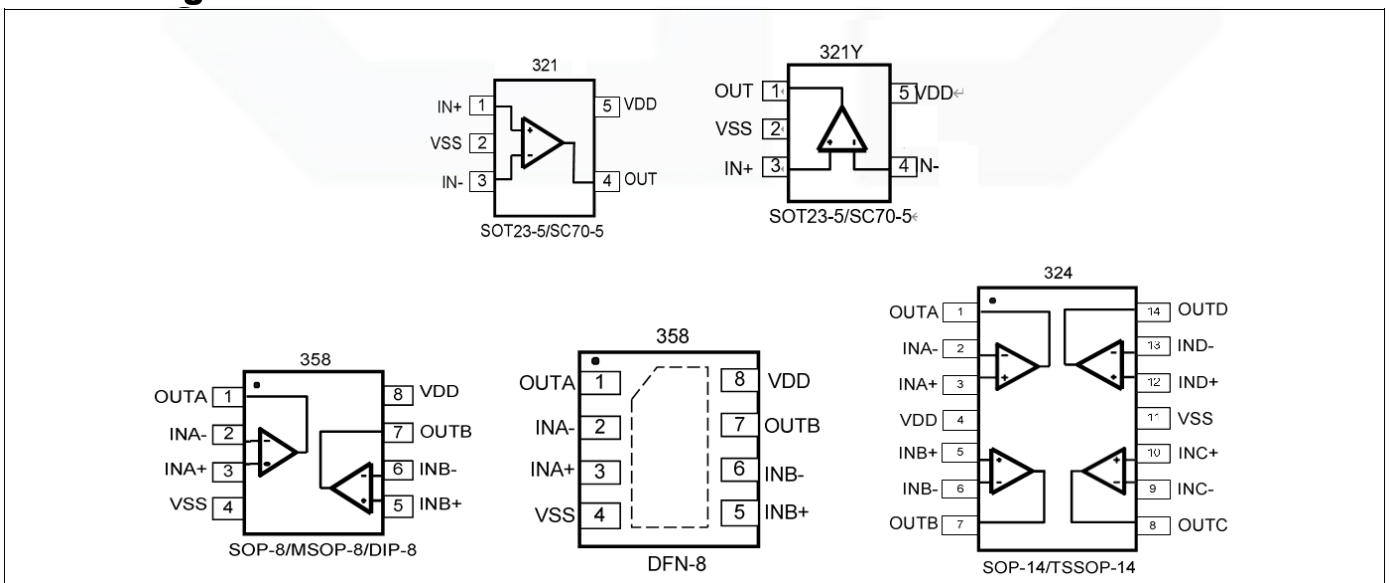

Figure 1. Pin Assignment Diagram

**Absolute Maximum Ratings**

Condition	Min	Max
Power Supply Voltage (V <sub>DD</sub> to V <sub>SS</sub> )	-0.5V	+7.5V
Analog Input Voltage (IN+ or IN-)	V <sub>SS</sub> -0.5V	V <sub>DD</sub> +0.5V
PDB Input Voltage	V <sub>SS</sub> -0.5V	+7V
Operating Temperature Range	-40°C	+125°C
Junction Temperature	+160°C	
Storage Temperature Range	-55°C	+150°C
Lead Temperature (soldering, 10sec)	+260°C	
<b>Package Thermal Resistance (T<sub>A</sub>=+25°C)</b>		
SOP-8, $\theta_{JA}$	125°C/W	
MSOP-8, $\theta_{JA}$	216°C/W	
SOT23-5, $\theta_{JA}$	190°C/W	
SC70-5, $\theta_{JA}$	333°C/W	
<b>ESD Susceptibility</b>		
HBM	6KV	
MM	300V	

**Note:** Stress greater than those listed under Absolute Maximum Ratings may cause permanent damage to the device. This is a stress rating only and functional operation of the device at these or any other conditions outside those indicated in the operational sections of this specification are not implied. Exposure to absolute maximum rating conditions for extended periods may affect reliability.

**Package/Ordering Information**

MODEL	CHANNEL	ORDER NUMBER	PACKAGE DESCRIPTION	PACKAGE OPTION	MARKING INFORMATION
MA321	Single	MA321-CR	SC70-5	Tape and Reel,3000	321
		MA321-TR	SOT23-5	Tape and Reel,3000	321
		MA321Y-CR	SC70-5	Tape and Reel,3000	321Y
		MA321Y-TR	SOT23-5	Tape and Reel,3000	321Y
MA358	Dual	MA358-SR	SOP-8	Tape and Reel,4000	MA358
		MA358-MR	MSOP-8	Tape and Reel,3000	MA358
		MA358-DR	DIP-8	20Tube(1000pcs)	MA358
		MA358-FR	DFN-8	Tape and Reel,3000	MA358
MA324	Quad	MA324-TR	TSSOP-14	Tape and Reel,3000	MA324
		MA324-SR	SOP-14	Tape and Reel,2500	MA324



**Electrical Characteristics**

(At  $V_S = +5V$ ,  $R_L = 100k\Omega$  connected to  $V_S/2$ , and  $V_{OUT} = V_S/2$ , unless otherwise noted.)

PARAMETER	SYMBOL	CONDITIONS	MA321/358/324				
			TYP	MIN/MAX OVER TEMPERATURE			
			+25°C	+25°C	-40°C to +85°C	UNITS	MIN/MAX
<b>INPUT CHARACTERISTICS</b>							
Input Offset Voltage	$V_{OS}$	$V_{CM} = V_S/2$	0.4	3.5	5.6	mV	MAX
Input Bias Current	$I_B$		1			pA	TYP
Input Offset Current	$I_{OS}$		1			pA	TYP
Common-Mode Voltage Range	$V_{CM}$	$V_S = 5.5V$	-0.1 to +5.6			V	TYP
Common-Mode Rejection Ratio	CMRR	$V_S = 5.5V, V_{CM} = -0.1V$ to 4V	70	62	62	dB	MIN
		$V_S = 5.5V, V_{CM} = -0.1V$ to 5.6V	68	56	55		
Open-Loop Voltage Gain	$A_{OL}$	$R_L = 5k\Omega, V_O = +0.1V$ to +4.9V	80	70	70	dB	MIN
		$R_L = 10k\Omega, V_O = +0.1V$ to +4.9V	100	94	85		
Input Offset Voltage Drift	$\Delta V_{OS}/\Delta T$		2.7			$\mu V/^\circ C$	TYP
<b>OUTPUT CHARACTERISTICS</b>							
Output Voltage Swing from Rail	$V_{OH}$	$R_L = 100k\Omega$	4.997	4.990	4.980	V	MIN
	$V_{OL}$	$R_L = 100k\Omega$	3	10	20	mV	MAX
	$V_{OH}$	$R_L = 10k\Omega$	4.992	4.970	4.960	V	MIN
	$V_{OL}$	$R_L = 10k\Omega$	8	30	40	mV	MAX
Output Current	$I_{SOURCE}$	$R_L = 10\Omega$ to $V_S/2$	84	60	45	mA	MIN
	$I_{SINK}$		75	60	45		
<b>POWER SUPPLY</b>							
Operating Voltage Range				2.1	2.5	V	MIN
				5.5	5.5	V	MAX
Power Supply Rejection Ratio	PSRR	$V_S = +2.5V$ to +5.5V, $V_{CM} = +0.5V$	82	60	58	dB	MIN
Quiescent Current / Amplifier	$I_Q$		40			$\mu A$	TYP
<b>DYNAMIC PERFORMANCE (CL = 100pF)</b>							
Gain-Bandwidth Product	GBP		1			MHz	TYP
Slew Rate	SR	$G = +1, 2V$ Output Step	0.6			V/ $\mu s$	TYP
Settling Time to 0.1%	$t_s$	$G = +1, 2V$ Output Step	5			$\mu s$	TYP
Overload Recovery Time		$V_{IN} \cdot Gain = V_S$	2.6			$\mu s$	TYP
<b>NOISE PERFORMANCE</b>							
Voltage Noise Density	$e_n$	f = 1kHz	27			nV / $\sqrt{Hz}$	TYP
		f = 10kHz	20			nV / $\sqrt{Hz}$	TYP



### Typical Performance characteristics

At  $T_A=+25^\circ\text{C}$ ,  $V_S=+5\text{V}$ , and  $R_L=100\text{K}\Omega$  connected to  $V_S/2$ , unless otherwise noted.

Large-Signal Step Response

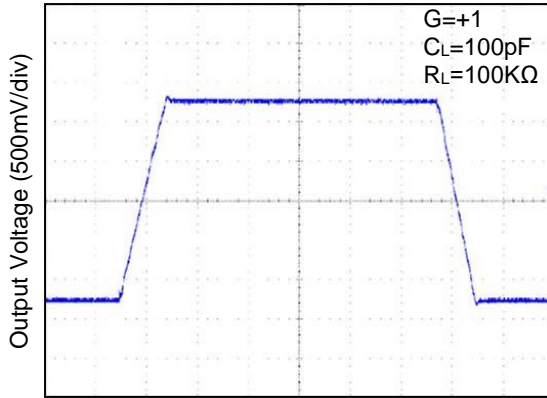

Time (4µs/div)

Small-Signal Step Response

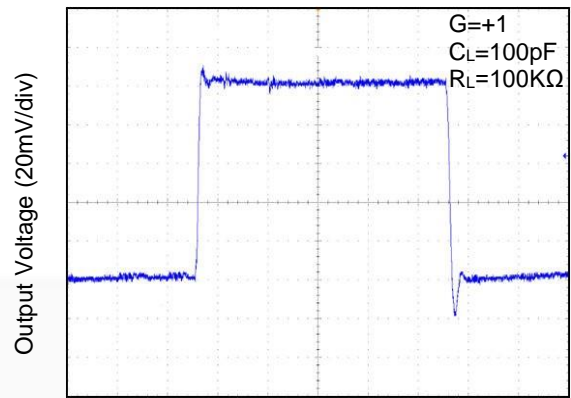

Time (2µs/div)

Supply Current vs. Supply Voltage

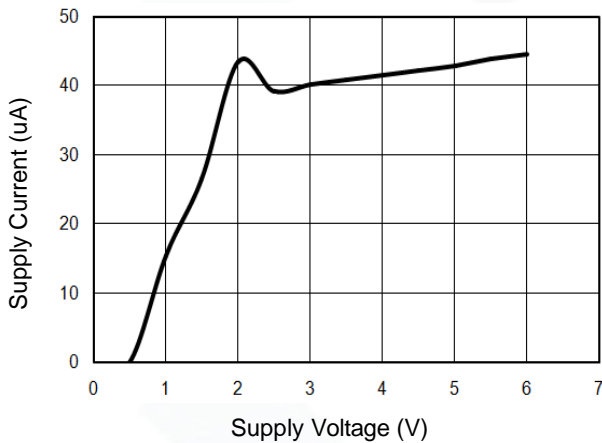

Short-Circuit Current vs. Supply Voltage

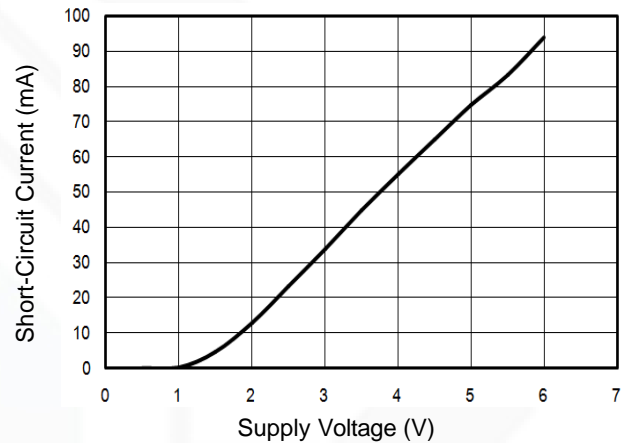

Output Voltage vs. Output Current

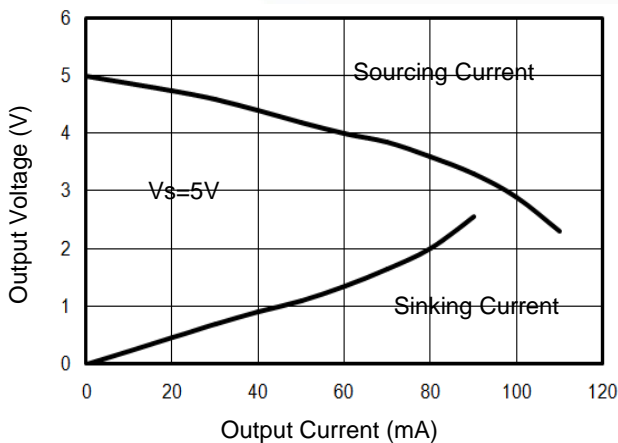

Output Voltage vs. Output Current

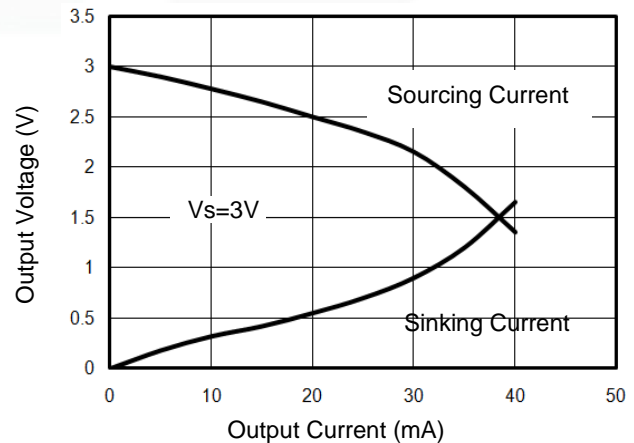



### Typical Performance characteristics

At  $T_A=+25^{\circ}\text{C}$ ,  $V_S=+5\text{V}$ , and  $R_L=100\text{K}\Omega$  connected to  $V_S/2$ , unless otherwise noted.

Overload Recovery Time

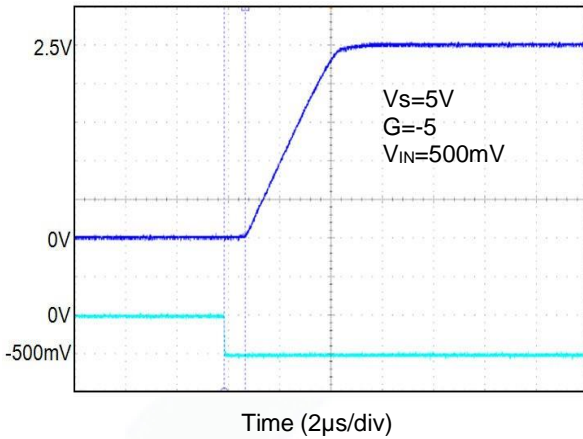

Supply Current vs. Temperature

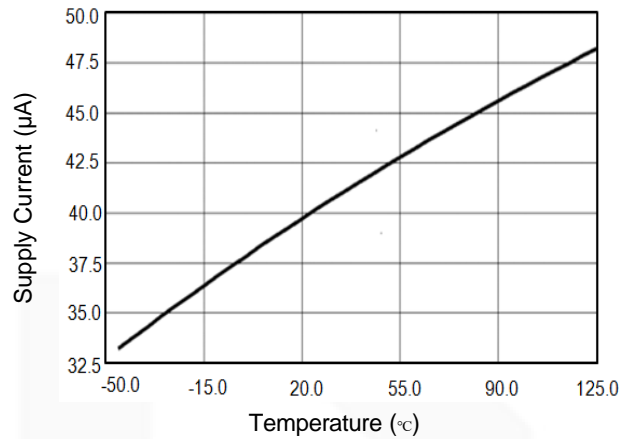

Input Voltage Noise Spectral Density vs. Frequency

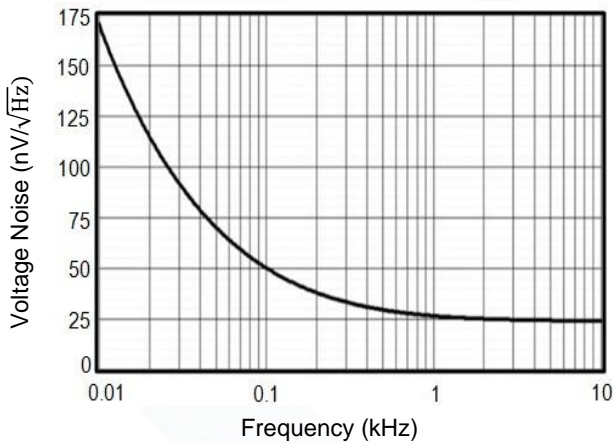

Open Loop Gain, Phase Shift vs. Frequency at +5V

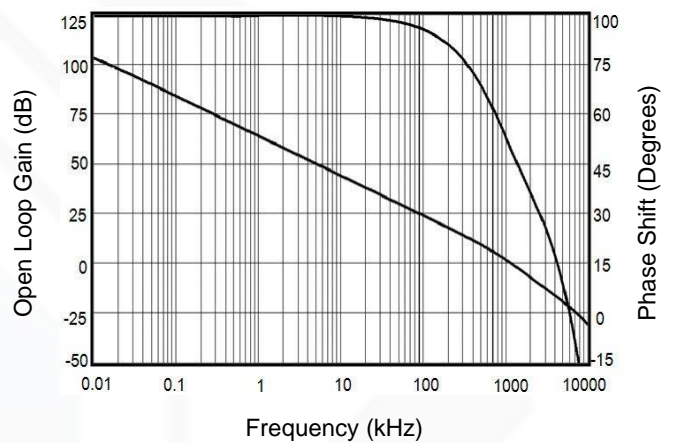

CMRR vs. Frequency

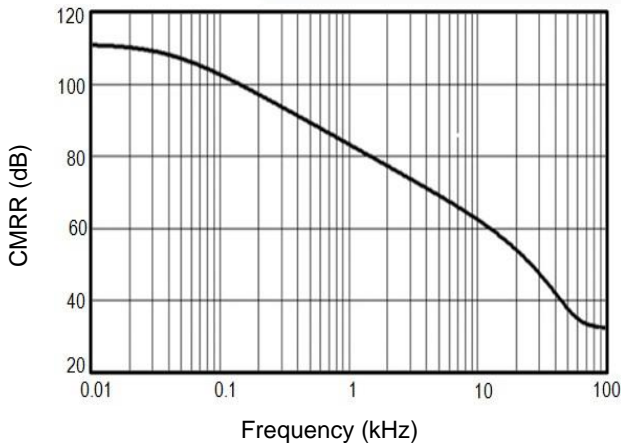

PSRR vs. Frequency

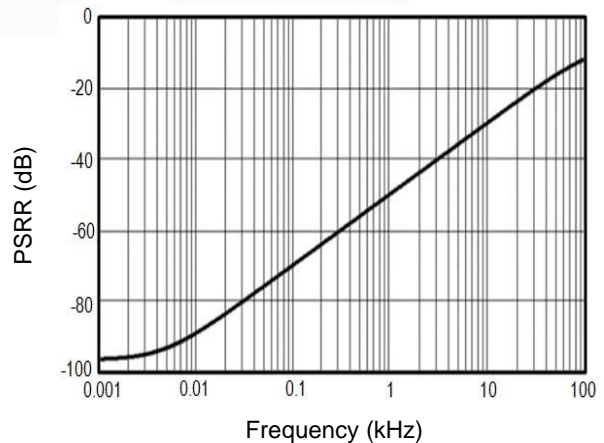



### Application Note

#### Size

MA321/358/324 family series op amps are unity-gain stable and suitable for a wide range of general-purpose applications. The small footprints of the MA321/358/324 family packages save space on printed circuit boards and enable the design of smaller electronic products.

#### Power Supply Bypassing and Board Layout

MA321/358/324 family series operates from a single 2.1V to 5.5V supply or dual  $\pm 1.05V$  to  $\pm 2.75V$  supplies. For best performance, a  $0.1\mu F$  ceramic capacitor should be placed close to the  $V_{DD}$  pin in single supply operation. For dual supply operation, both  $V_{DD}$  and  $V_{SS}$  supplies should be bypassed to ground with separate  $0.1\mu F$  ceramic capacitors.

#### Low Supply Current

The low supply current (typical  $40\mu A$  per channel) of MA321/358/324 family will help to maximize battery life. They are ideal for battery powered systems.

#### Operating Voltage

MA321/358/324 family operates under wide input supply voltage (2.1V to 5.5V). In addition, all temperature specifications apply from  $-40\text{ }^{\circ}C$  to  $+125\text{ }^{\circ}C$ . Most behavior remains unchanged throughout the full operating voltage range. These guarantees ensure operation throughout the single Li-Ion battery lifetime.

#### Rail-to-Rail Input

The input common-mode range of MA321/358/324 family extends  $100mV$  beyond the supply rails ( $V_{SS}-0.1V$  to  $V_{DD}+0.1V$ ). This is achieved by using complementary input stage. For normal operation, inputs should be limited to this range.

#### Rail-to-Rail Output

Rail-to-Rail output swing provides maximum possible dynamic range at the output. This is particularly important when operating in low supply voltages. The output voltage of MA321/358/324 family can typically swing to less than  $5mV$  from supply rail in light resistive loads ( $>100k\Omega$ ), and  $30mV$  of supply rail in moderate resistive loads ( $10k\Omega$ ).

#### Capacitive Load Tolerance

The MA321/358/324 family is optimized for bandwidth and speed, not for driving capacitive loads. Output capacitance will create a pole in the amplifier's feedback path, leading to excessive peaking and potential oscillation. If dealing with load capacitance is a requirement of the application, the two strategies to consider are (1) using a small resistor in series with the amplifier's output and the load capacitance and (2) reducing the bandwidth of the amplifier's feedback loop by increasing the overall noise gain. Figure 2. shows a unity gain follower using the series resistor strategy. The resistor isolates the output from the capacitance and, more importantly, creates a zero in the feedback path that compensates for the pole created by the output capacitance.

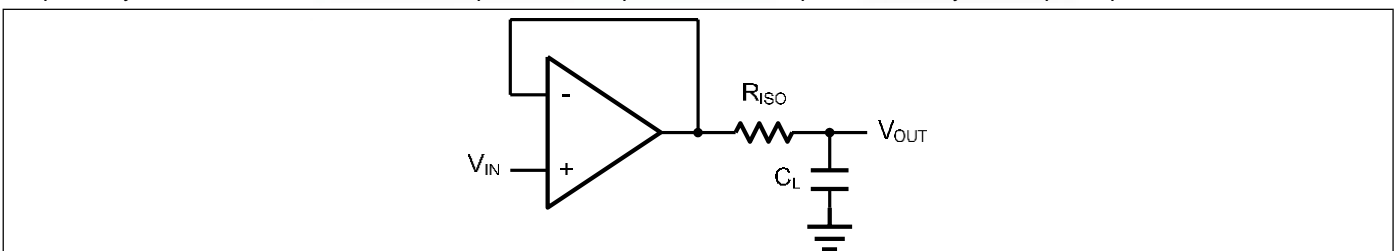

Figure 2. Indirectly Driving a Capacitive Load Using Isolation Resistor



1MHz CMOS Rail-to-Rail IO Opamp with RF Filter

The bigger the  $R_{ISO}$  resistor value, the more stable  $V_{OUT}$  will be. However, if there is a resistive load  $R_L$  in parallel with the capacitive load, a voltage divider (proportional to  $R_{ISO}/R_L$ ) is formed, this will result in a gain error.

The circuit in Figure 3 is an improvement to the one in Figure 2.  $R_F$  provides the DC accuracy by feed-forward the  $V_{IN}$  to  $R_L$ .  $C_F$  and  $R_{ISO}$  serve to counteract the loss of phase margin by feeding the high frequency component of the output signal back to the amplifier's inverting input, thereby preserving the phase margin in the overall feedback loop. Capacitive drive can be increased by increasing the value of  $C_F$ . This in turn will slow down the pulse response.

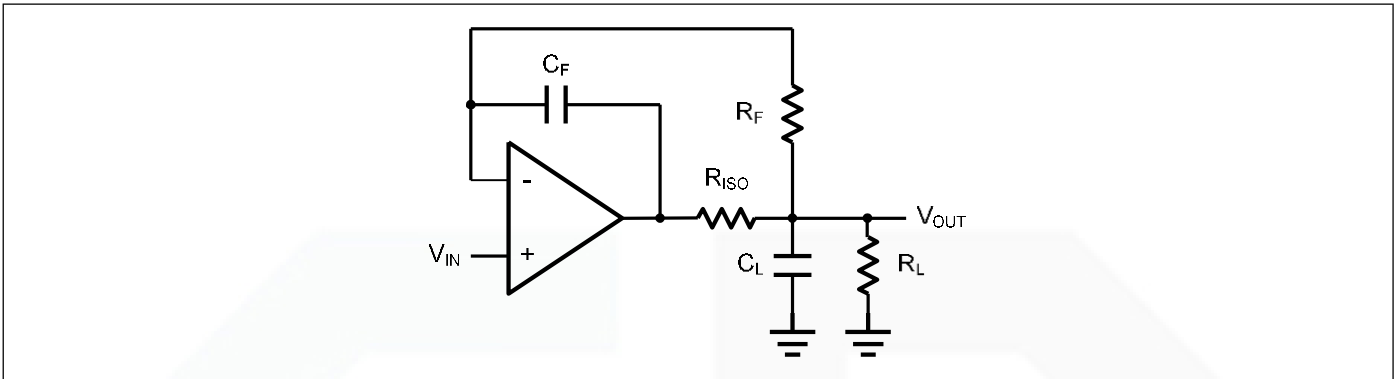

Figure 3. Indirectly Driving a Capacitive Load with DC Accuracy

## Typical Application Circuits

### Differential amplifier

The differential amplifier allows the subtraction of two input voltages or cancellation of a signal common to the two inputs. It is useful as a computational amplifier in making a differential to single-end conversion or in rejecting a common mode signal. Figure 4. shows the differential amplifier using MA321/358/324 family.

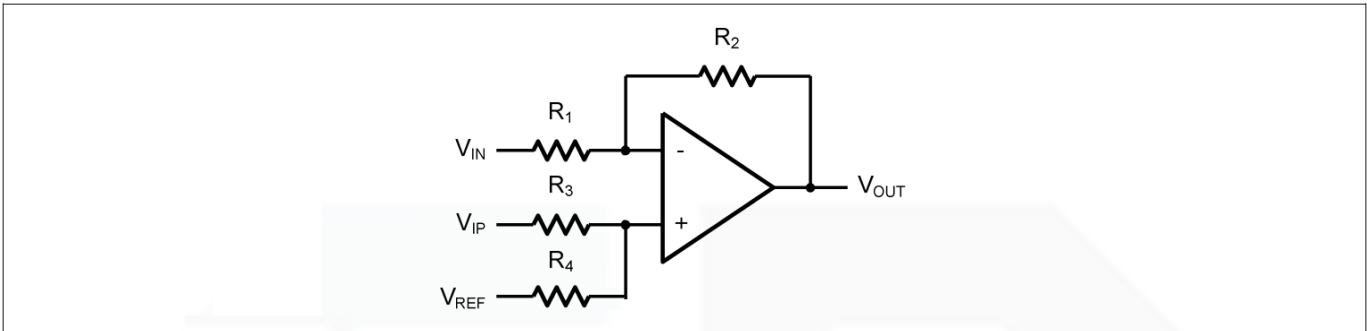

Figure 4. Differential Amplifier

$$V_{OUT} = \left( \frac{R_1+R_2}{R_3+R_4} \right) \frac{R_4}{R_1} V_{IN} - \frac{R_2}{R_1} V_{IP} + \left( \frac{R_1+R_2}{R_3+R_4} \right) \frac{R_3}{R_1} V_{REF}$$

If the resistor ratios are equal (i.e.  $R_1=R_3$  and  $R_2=R_4$ ), then

$$V_{OUT} = \frac{R_2}{R_1} (V_{IP} - V_{IN}) + V_{REF}$$

### Low Pass Active Filter

The low pass active filter is shown in Figure 5. The DC gain is defined by  $-R_2/R_1$ . The filter has a -20dB/decade roll-off after its corner frequency  $f_c=1/(2\pi R_3 C_1)$ .

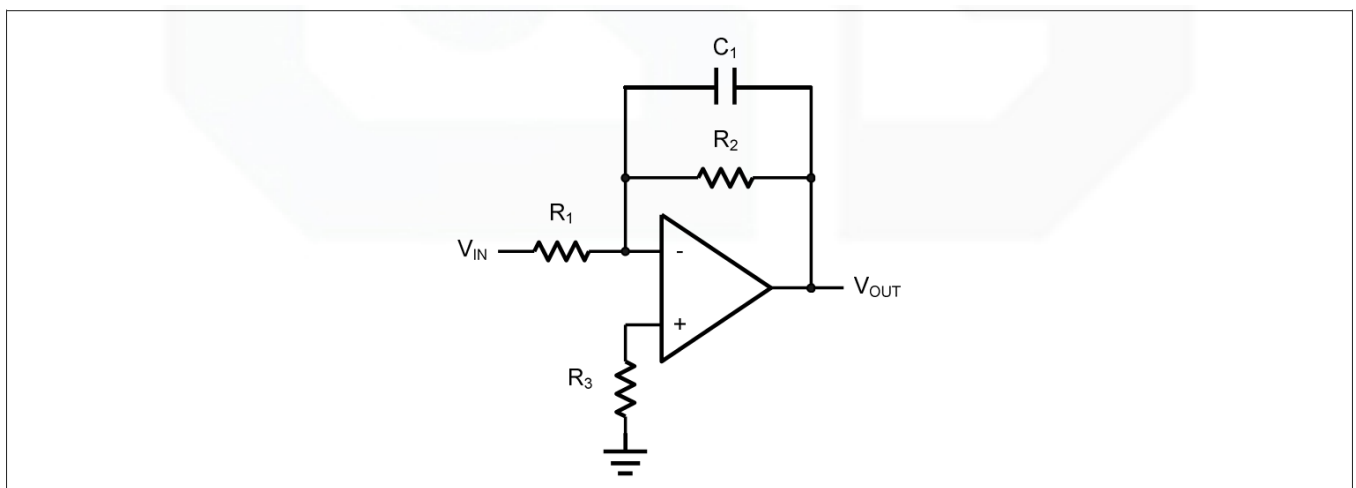

Figure 5. Low Pass Active Filter



**Instrumentation Amplifier**

The triple MA321/358/324 family can be used to build a three-op-amp instrumentation amplifier as shown in Figure 6. The amplifier in Figure 6 is a high input impedance differential amplifier with gain of  $R_2/R_1$ . The two differential voltage followers assure the high input impedance of the amplifier.

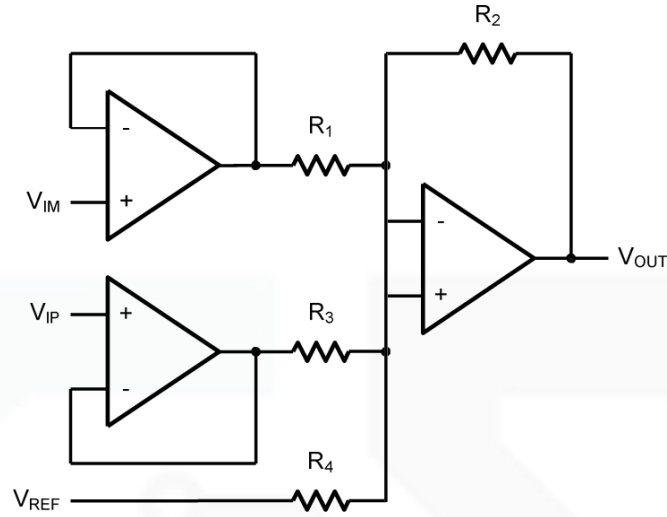
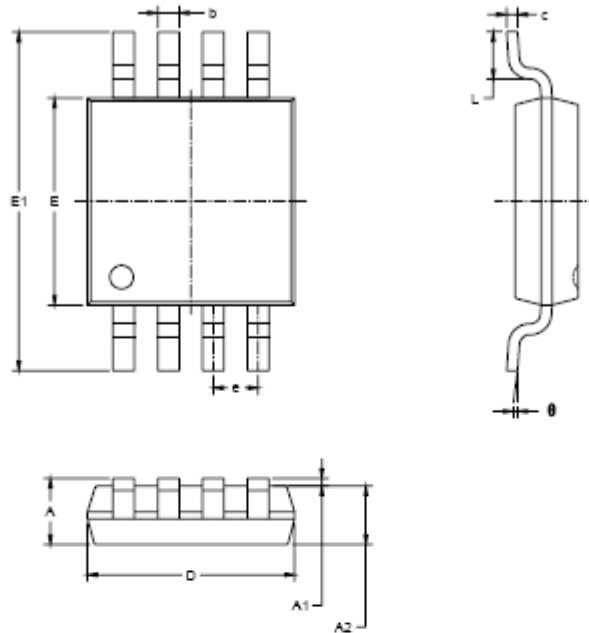

Figure 6. Instrument Amplifier



Package Information

MSOP-8



Symbol	Dimensions In Millimeters		Dimensions In Inches	
	MIN	MAX	MIN	MAX
A	0.620	1.100	0.032	0.043
A1	0.020	0.150	0.001	0.008
A2	0.750	0.950	0.030	0.037
b	0.250	0.380	0.010	0.015
c	0.090	0.230	0.004	0.009
D	2.900	3.100	0.114	0.122
E	2.900	3.100	0.114	0.122
E1	4.750	5.050	0.187	0.199
e	0.650 BSC		0.026 BSC	
L	0.400	0.800	0.016	0.031
θ	0°	8°	0°	8°



SOP-8

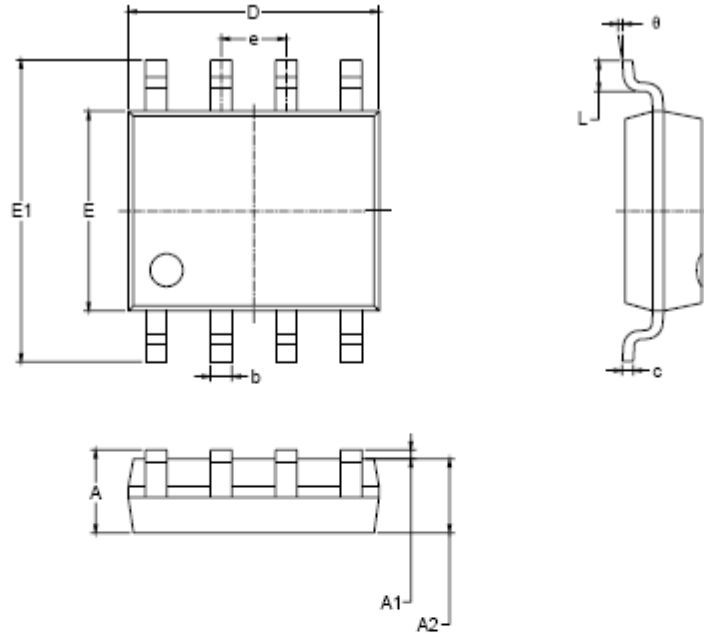

Symbol	Dimensions In Millimeters		Dimensions In Inches	
	MIN	MAX	MIN	MAX
A	1.350	1.750	0.053	0.069
A1	0.100	0.250	0.004	0.010
A2	1.350	1.560	0.053	0.061
b	0.330	0.510	0.013	0.020
c	0.170	0.260	0.006	0.010
D	4.700	5.100	0.185	0.200
E	3.800	4.000	0.150	0.157
E1	5.800	6.200	0.228	0.244
e	1.27 BSC		0.050 BSC	
L	0.400	1.270	0.016	0.050
θ	0°	8°	0°	8°



SOT23-5

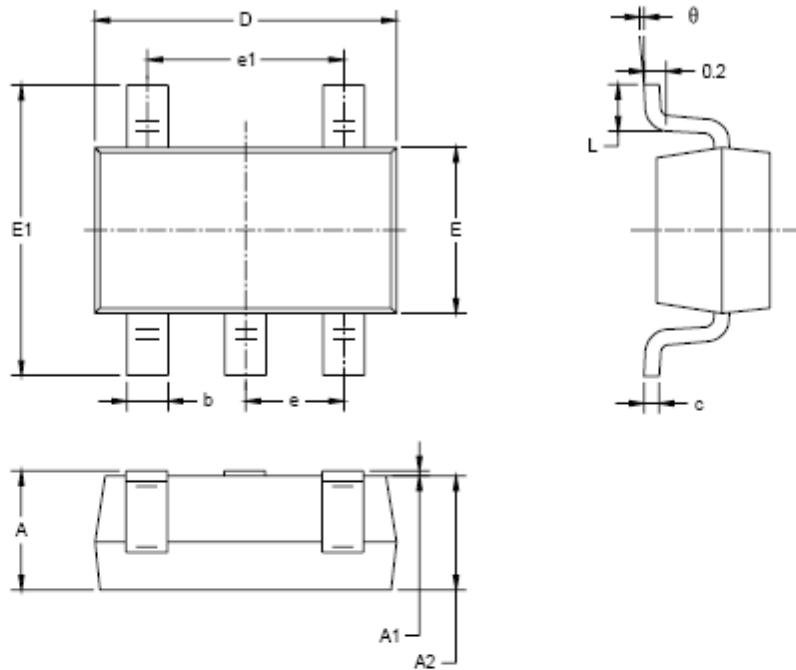

Symbol	Dimensions In Millimeters		Dimensions In Inches	
	MIN	MAX	MIN	MAX
A	1.050	1.250	0.041	0.049
A1	0.000	0.100	0.000	0.004
A2	1.050	1.150	0.041	0.045
b	0.300	0.500	0.012	0.020
c	0.100	0.200	0.004	0.008
D	2.820	3.020	0.111	0.119
E	1.500	1.700	0.059	0.067
E1	2.650	2.950	0.104	0.116
e	0.950 BSC		0.037 BSC	
e1	1.900 BSC		0.075 BSC	
L	0.300	0.600	0.012	0.024
θ	0°	8°	0°	8°



TSSOP-14

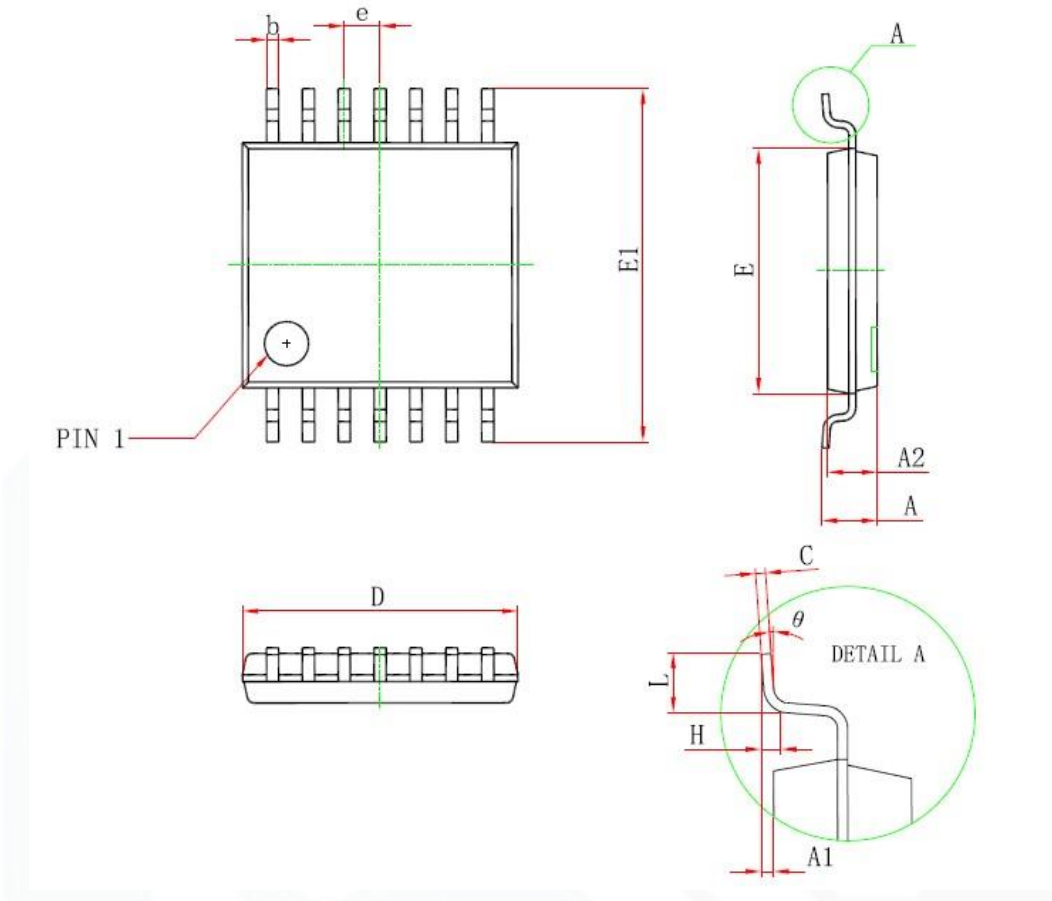

Symbol	Dimensions In Millimeters		Dimensions In Inches	
	Min	Max	Min	Max
D	4.900	5.100	0.193	0.201
E	4.300	4.500	0.169	0.177
b	0.190	0.300	0.007	0.012
c	0.090	0.200	0.004	0.008
E1	6.250	6.550	0.246	0.258
A		1.200		0.047
A2	0.800	1.000	0.031	0.039
A1	0.050	0.150	0.002	0.006
e	0.65 (BSC)		0.026 (BSC)	
L	0.500	0.700	0.020	0.028
H	0.25(TYP)		0.01(TYP)	
$\theta$	1°	7°	1°	7°



SC70-5

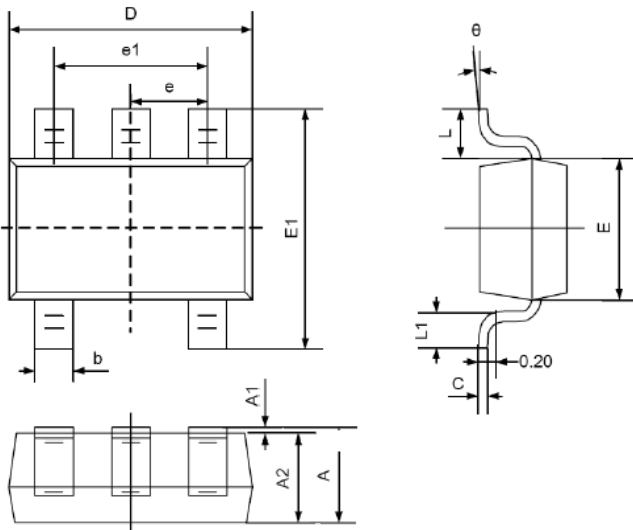

Symbol	Dimensions In Millimeters		Dimensions In Inches	
	Min	Max	Min	Max
A	0.900	1.100	0.035	0.043
A1	0.000	0.100	0.000	0.004
A2	0.900	1.000	0.035	0.039
b	0.150	0.350	0.006	0.014
C	0.080	0.150	0.003	0.006
D	2.000	2.200	0.079	0.087
E	1.150	1.350	0.045	0.053
E1	2.150	2.450	0.085	0.096
e	0.650TYP		0.026TYP	
e1	1.200	1.400	0.047	0.055
L	0.525REF		0.021REF	
L1	0.260	0.460	0.010	0.018
θ	0°	8°	0°	8°



SOP-14

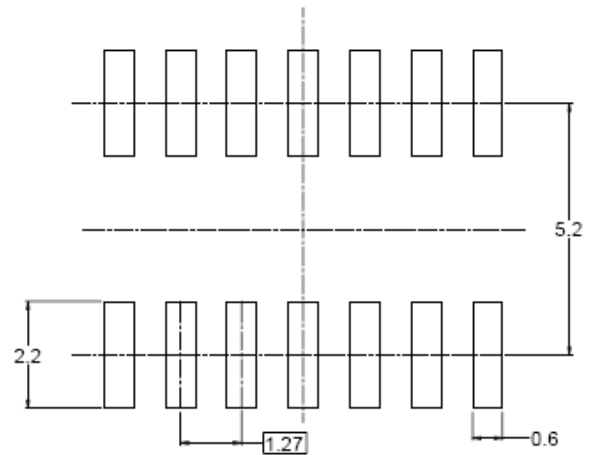
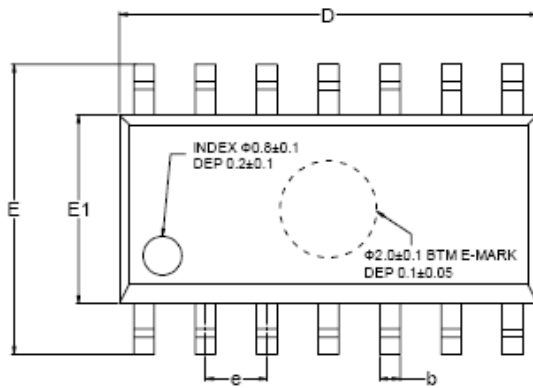

RECOMMENDED LAND PATTERN (Unit: mm)

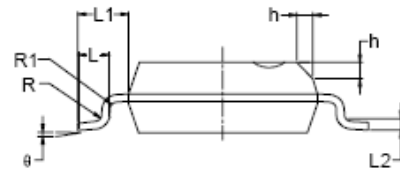
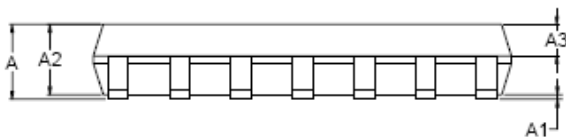

Symbol	Dimensions In Millimeters			Dimensions In Inches		
	MIN	MOD	MAX	MIN	MOD	MAX
A	1.35		1.75	0.053		0.069
A1	0.10		0.25	0.004		0.010
A2	1.25		1.65	0.049		0.065
A3	0.55		0.75	0.022		0.030
b	0.36		0.49	0.014		0.019
D	8.53		8.73	0.336		0.344
E	5.80		6.20	0.228		0.244
E1	3.80		4.00	0.150		0.157
e	1.27 BSC			0.050 BSC		
L	0.45		0.80	0.018		0.032
L1	1.04 REF			0.040 REF		
L2	0.25 BSC			0.01 BSC		
R	0.07			0.003		
R1	0.07			0.003		
h	0.30		0.50	0.012		0.020
$\theta$	0°		8°	0°		8°



**DFN-8**

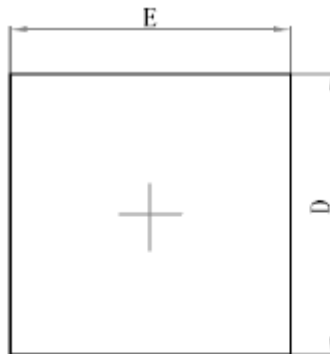

**Top View**

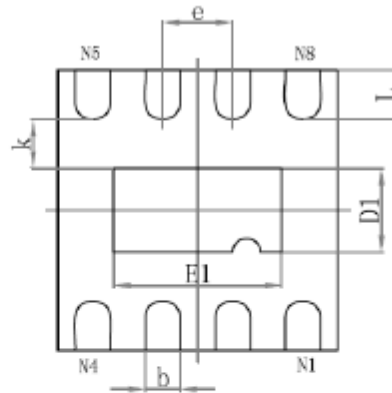

**Bottom View**

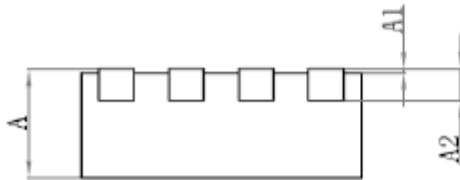

**Side View**

Symbol	Dimensions In Millimeters			Dimensions In Inches		
	Min	Nom	Max	Min	Nom	Max
A	0.80	0.85	0.9	0.031	0.033	0.035
A1	0.00	0.02	0.05	0.000	0.001	0.002
A2	0.153	0.203	0.253	0.006	0.008	0.010
b	0.18	0.24	0.30	0.007	0.009	0.012
D	1.9	2.0	2.1	0.075	0.079	0.083
E	1.9	2.0	2.1	0.075	0.079	0.083
D1	0.5	0.6	0.7	0.020	0.024	0.028
E1	1.1	1.2	1.3	0.043	0.047	0.051
e		0.50			0.20	
k	0.2			0.008		
L	0.25	0.35	0.45	0.010	0.014	0.018



***CBC Microelectronics Co.,Ltd***

*<http://www.cbcv.net>*

**IMPORTANT NOTICE**

CBC Microelectronics Co., Ltd reserves the right to make modifications, enhancements, improvements, corrections or other changes without further notice to this document and any product described herein or to discontinue any product or service. Customers should obtain the latest relevant information before placing orders and should verify the latest and complete information. CBC Microelectronics does not assume any responsibility for use of any product, nor does CBC Microelectronics any liability arising out of the application or use of this document or any product or circuit described herein. CBC Microelectronics assumes no liability for applications assistance or the design of Customers' products. Customers are responsible for their products and applications using CBC Microelectronics components. CBC Microelectronics does not convey any license under its patent or trademark rights nor the other rights.

CBC Microelectronics Co., Ltd © 2004-2021.