



### Features

- Low power consumption
- Low voltage drop
- Low temperature coefficient
- Low Quiescent Current: 5uA at 6V
- Output voltage accuracy: tolerance  $\pm 2\%$

### Applications

- Battery-powered equipment
- Reference voltage sources
- Cameras, video cameras
- Portable AV systems
- Mobile phones
- Portable games

### General Description

MB6216 series are a highly precise, lower consumption, 3 terminal, positive voltage regulators manufactured using CMOS and laser trimming technologies. The series provides large currents with a significantly small dropout voltage .

The MB6216 consists of a current limiter circuit, a driver transistor, a precision reference voltage and an error correction circuit. The series is

compatible with low ESR ceramic capacitors. The current limiter's foldback circuit operates as a short circuit protection as well as the output current limiter for the output pin. Output voltages are internally by laser trimming technologies. It is selectable in 0.1V increments within a range of 1.2V to 3.6V. MB6216 series are available in SOT-23 、SOT23-3and SOT-89 packages.

### Order Information

**MB6216-①②③④⑤**

Designator	Symbol	Description
①②	Integer	Output Voltage(1.2~3.6V)
③	--	Normal
	G	Standard
④	N	Package:SOT23
	M	Package:SOT23-3
	P	Package:SOT89
⑤	R	RoHS / Pb Free
	G	Halogen Free

Note: "①②" stands for output voltages. Other voltages can be specially customized



**Block Diagram**

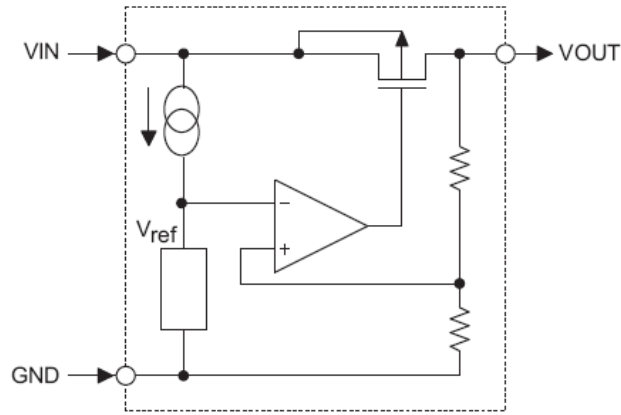

**Pin Assignment**

SOT23 and SOT23-3 (Top View) Table1: MB6216-XXNR/MB6216-XXMR series (SOT23/SOT23-3 PKG)

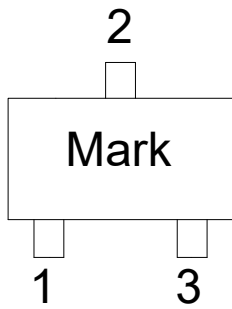

PIN NO.	PIN NAME	FUNCTION
1	GND	GND pin
2	VIN	Input voltage pin
3	VOUT	Output voltage pin

SOT89 (Top View)

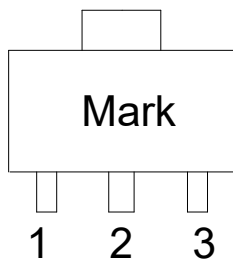
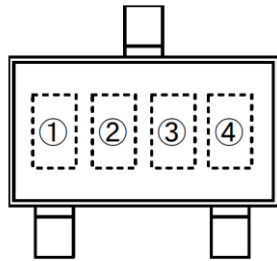

Table2: MB6216-XXPR series (SOT89 PKG)

PIN NO.	PIN NAME	FUNCTION
1	GND	GND pin
2	VIN	Input voltage pin
3	VOUT	Output voltage pin



**Marking Rule**



SOT-23  
(TOP VIEW)

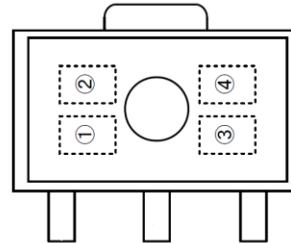

SOT-89  
(TOP VIEW)

Product Name	Product Code			
	(1)	(2)	(3)	(4)
MB6216-15	6	5	E	9
MB6216-18	6	5	K	5
MB6216-25	6	5	T	5
MB6216-28	5	4	F	K
MB6216-30	6	5	Z	5
MB6216-33	6	6	2	K
MB6216-36	6	6	5	K



**300mA Low Power LDO**

**Absolute Maximum Ratings**

Parameter		Symbol	Ratings	Units
Input Voltage		$V_{IN}$	8	V
Output Current		$I_{OUT}$	300*	mA
Output Voltage		$V_{OUT}$	$V_{SS}-0.3\sim V_{IN}+0.3$	V
Power Dissipation	SOT-23	$P_d$	0.20	W
	SOT23-3		0.25	W
	SOT-89		0.50	W
Operating Temperature Range		$T_{opr}$	-40~+85	°C
Storage Temperature Range		$T_{stg}$	-55~+125	°C

\* $I_{OUT}=P_d/(V_{IN}-V_{OUT})$

**Electrical Characteristics**

MB6216 for any output voltage  
( $T_a=25^\circ\text{C}$ )

Parameter	Symbol	Conditions	Min.	Typ.	Max.	Unit
Output Voltage	$V_{out}$	$V_{in}=V_{out}+1V$ $1.0mA \leq I_{out} \leq 30mA$	$V_{out} \times 0.98$	--	$V_{out} \times 1.02$	V
Output Current*1	$I_{out}$	$V_{in}-V_{out}=1V$	--	300	--	mA
Low dropout*2	$V_{drop}$	Refer to the next table				
Line Regulation	$\Delta V_{out} / (V_{in}-V_{out})$	$1.6V \leq V_{in} \leq 8V$ $I_{out}=40mA$	--	0.05	0.2	%/V
Load Regulation	$\Delta V_{out} / \Delta I_{out}$	$V_{in}=V_{out}+1V$ $1.0mA \leq I_{out} \leq 80mA$	--	12	30	mV
Output voltage Temperature coefficient	$\Delta V_{out} / (T_a \cdot V_{out})$	$I_{out}=30mA$ $0^\circ\text{C} \leq T_a \leq 70^\circ\text{C}$	--	$\pm 100$	--	Ppm/°C
Supply Current	$I_{ss}$	$V_{in}=6V$	--	5	10	uA
Input Voltage	$V_{in}$	--	--	6	8	V
PSRR	PSRR	$F=1KHz$ $V_{in}=V_{out}+1V$	--	50	--	dB

**Electrical Characteristics by Output Voltage:**

Output Voltage $V_{out}(V)$	Dropout Voltage $V_{dif}$ (V)		
	Conditions	Typ.	Max.
$V_{out} \leq 1.5V$	$I_{out}=100mA$	0.50	0.68
$1.8 \leq V_{out} \leq 2$		0.39	0.53
$2.8 \leq V_{out} \leq 5.0$		0.23	0.39

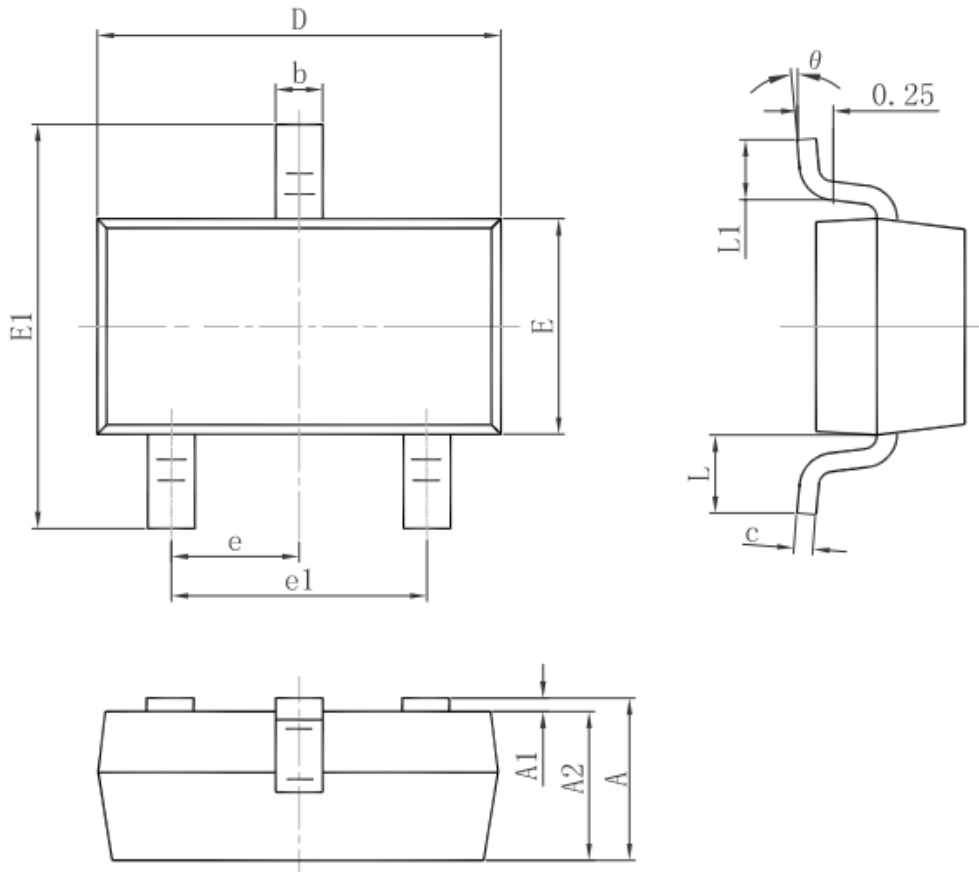
**Package Information**  
**3-pin SOT23 Outline Dimensions**

Symbol	Dimensions In Millimeters		Dimensions In Inches	
	Min.	Max.	Min.	Max.
A	0.900	1.150	0.035	0.045
A1	0.000	0.100	0.000	0.004
A2	0.900	1.050	0.035	0.041
b	0.300	0.500	0.012	0.020
c	0.080	0.150	0.003	0.006
D	2.800	3.000	0.110	0.118
E	1.200	1.400	0.047	0.055
E1	2.250	2.550	0.089	0.100
e	0.950 TYP.		0.037 TYP.	
e1	1.800	2.000	0.071	0.079
L	0.550 REF.		0.022 REF.	
L1	0.300	0.500	0.012	0.020
$\theta$	0°	8°	0°	8°



**3-pin SOT23-3 Outline Dimensions**

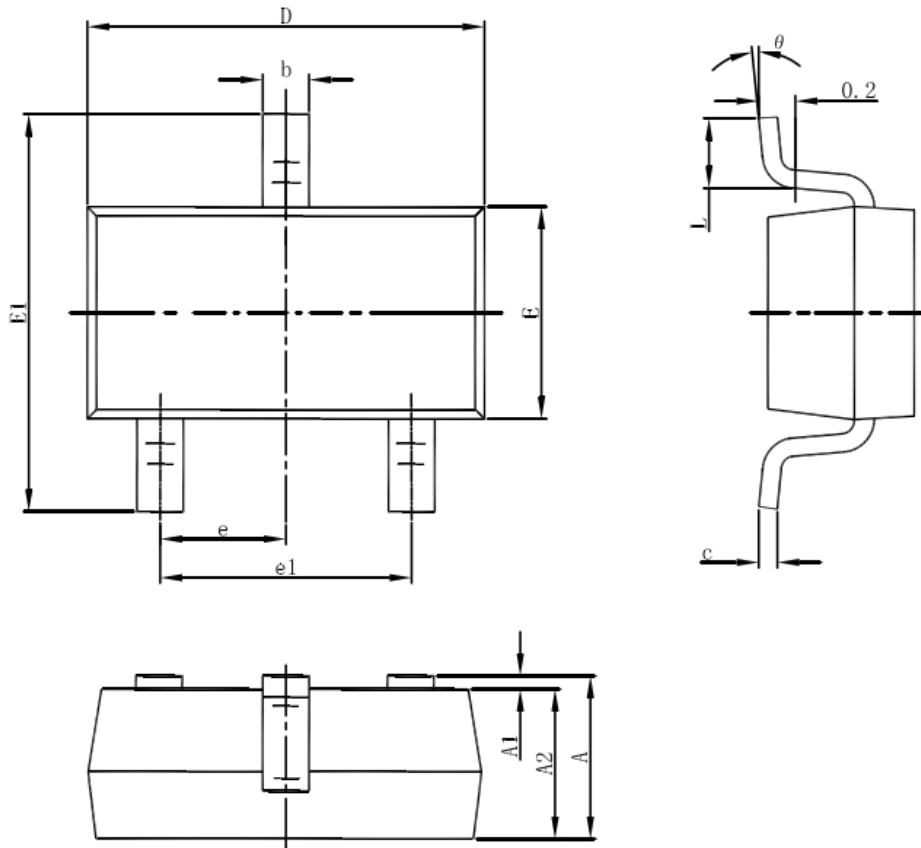

Symbol	Dimensions In Millimeters		Dimensions In Inches	
	Min	Max	Min	Max
A	1.050	1.250	0.041	0.049
A1	0.000	0.100	0.000	0.004
A2	1.050	1.150	0.041	0.045
b	0.300	0.500	0.012	0.020
c	0.100	0.200	0.004	0.008
D	2.820	3.020	0.111	0.119
E	1.500	1.700	0.059	0.067
E1	2.650	2.950	0.104	0.116
e	0.950(BSC)		0.037(BSC)	
e1	1.800	2.000	0.071	0.079
L	0.300	0.600	0.012	0.024
theta	0°	8°	0°	8°

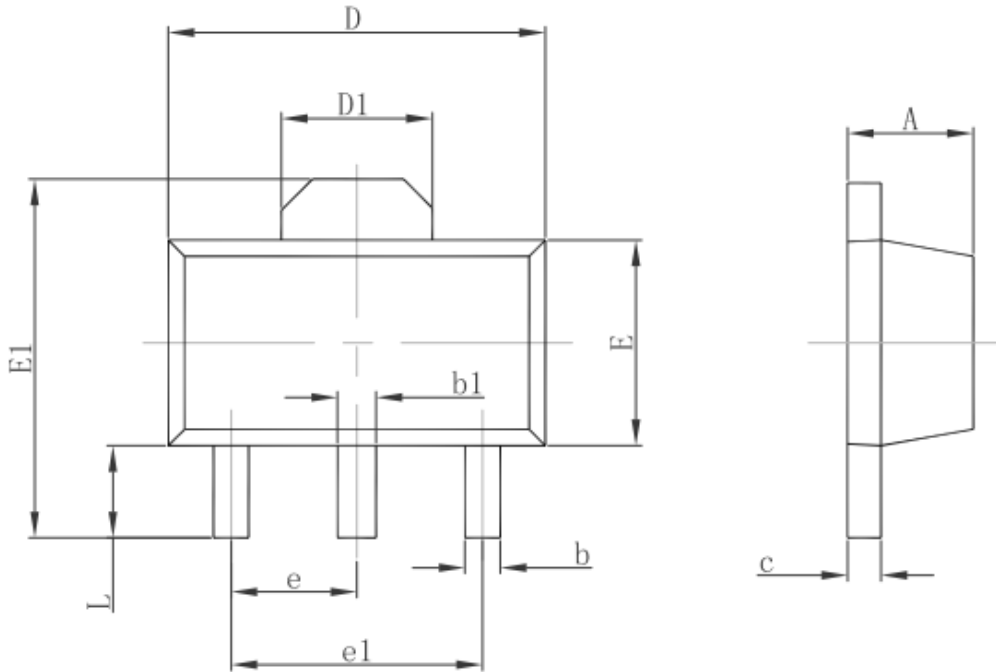
**3-pin SOT89 Outline Dimensions**

Symbol	Dimensions In Millimeters		Dimensions In Inches	
	Min.	Max.	Min.	Max.
A	1.400	1.600	0.055	0.063
b	0.320	0.520	0.013	0.020
b1	0.400	0.580	0.016	0.023
c	0.350	0.440	0.014	0.017
D	4.400	4.600	0.173	0.181
D1	1.550 REF.		0.061 REF.	
E	2.300	2.600	0.091	0.102
E1	3.940	4.250	0.155	0.167
e	1.500 TYP.		0.060 TYP.	
e1	3.000 TYP.		0.118 TYP.	
L	0.900	1.200	0.035	0.047

***CBC Microelectronics Co.,Ltd***

*<http://www.cbcv.net>*

**IMPORTANT NOTICE**

CBC Microelectronics Co., Ltd reserves the right to make modifications, enhancements, improvements, corrections or other changes without further notice to this document and any product described herein or to discontinue any product or service. Customers should obtain the latest relevant information before placing orders and should verify the latest and complete information. CBC Microelectronics does not assume any responsibility for use of any product, nor does CBC Microelectronics any liability arising out of the application or use of this document or any product or circuit described herein. CBC Microelectronics assumes no liability for applications assistance or the design of Customers' products. Customers are responsible for their products and applications using CBC Microelectronics components. CBC Microelectronics does not convey any license under its patent or trademark rights nor the other rights.

CBC Microelectronics Co., Ltd © 2004-2019.